

AQUA-THERM

“The Heating Professionals Choice”

Outdoor Wood Burning Appliances

Installation and Operation Manual

For the Aqua-Therm and Eco-One open and closed systems

VERIFY WITH INSURANCE COMPANY AND ALL LOCAL CODES AND ORDINANCES
PRIOR TO INSTALLATION.

IT IS THE OWNER'S RESPONSIBILITY TO ENSURE THAT THE APPLIANCE IS
ACCEPTABLE TO THEIR INSURANCE CARRIER AND THAT THE APPLIANCE
MEETS ALL LOCAL CODES AND ORDINANCES.

Thank you for purchasing the **AQUA-THERM** Outdoor Wood Burning Appliance.

The **AQUA-THERM** is a quality Outdoor Wood Burning Appliance designed to effectively heat structures. Please read and follow all safety instructions to ensure optimal performance.

The installation and operation of the **AQUA-THERM** is quite simple. Nevertheless, we recommend that the instructions be carefully read and followed. Pay particular attention to chimney and chimney connector installation as they present the greatest fire danger.

If you have any questions on the installation or operation of your **AQUA-THERM**, please contact your local **AQUA-THERM** Representative.

OBSERVE AND FOLLOW ALL SAFETY INSTRUCTIONS

Failure to install properly or follow safety instructions could result in severe personal injury, death or substantial property damage.

Hazard definitions

The following defined terms are used throughout this manual to bring attention to the presence of hazards of various risk levels or to important information concerning the life of the product.

DANGER

Indicates presence of hazards that will cause severe personal injury, death or substantial property damage.

WARNING

Indicates presence of hazards that can cause severe personal injury, death or substantial property damage.

CAUTION

Indicates presence of hazards that will or can cause minor personal injury or property damage.

NOTICE

Indicates special instructions on installation, operation or maintenance that are important but not related to personal injury or property damage.

Owner's registration card must be completed and returned to Aqua-Therm for warranty to be in effect.

SAVE THESE INSTRUCTIONS

Please fill in the following blanks and have this manual available when you call your local Aqua-Therm representative for assistance.

Model # _____

Serial # _____

Date of Purchase _____

Date of Installation _____

Dealer Name _____

Dealer Phone # _____

CONTENTS

1. GENERAL	
Safety	4
Specifications	5
Product Description	6
2. INSTALLATION	
Installation Tips	8
Placement	9
Clearances	10
Site Preparation	11
Transfer Line Installation	12
Lifting	14
Contents	15
Insulation Blanket	16
Venting Installation	18
Tapping Diagram	19
Plumbing Installation	20
Electrical Installation	22
Typical System Schematics	28
Accessories: Side Arm Heat Exchanger.....	35
Accessories: Exhaust Draft Hood	36
3. START-UP	
Initial Fill	37
Start up Checklist	40
4. OPERATION	
Initial Start-up	41
Operation	42
Maintenance	43
5. TROUBLESHOOTING	46
6. REPAIR PARTS	48
7. WARRANTY	51

SAFETY

ALL STATE or LOCAL CODES take precedence and MUST be observed

Many of these recommendations are based upon the National Fire Protection Assn. Code 211. Before installing or starting operation, read and familiarize yourself with all instructions. Installation is to be performed only by qualified heating professionals.

DANGER: RISK OF EXPLOSION OR PERSONAL INJURY

- ◆ Ensure that blower is 'OFF' prior to opening loading door or ash door. Failure to do so could result in severe burns.
- ◆ ALWAYS hesitate momentarily between the first and second latches when opening doors to allow unburned gases to ignite. Failure to do so could result in severe burns.
- ◆ DO NOT use chemicals, kerosene or other flammable liquids to start a fire; severe burns could result.
- ◆ DO NOT store combustible liquids or materials near the appliance.
- ◆ DO NOT store wood within the minimum clearance to combustibles.
- ◆ DO NOT burn gasoline, naphtha or engine oil.
- ◆ DO NOT burn garbage, tires, telephone poles, railroad ties or yard waste. In many areas this is illegal and will damage the appliance. Burning anything other than wood can void your warranty.
- ◆ DO NOT start a fire if flammable vapors or dust are present. An explosion could result.
- ◆ Most anti-freeze is glycol based. Never store glycol of any kind near the appliance or any potential ignition source. All glycol is flammable when exposed to high temperatures. If glycol is allowed to accumulate in or around the appliance or any other potential ignition source, a fire can develop.
- ◆ Never use automotive anti-freeze or ethylene glycol in the system. Using these glycols can destroy rubber pump and valve seals leading to hazardous leakage and system damage.
- ◆ Monitor and inspect the system and appliance regularly for leakage. Repair any leaks immediately to prevent possible accumulation of glycol.
- ◆ **NEVER** operate without a properly installed pressure relief valve (Watts Regulator M335 or equivalent), which will discharge water and relieve pressure at 30 psi. Use only a boiler relief valve designed to lift at 30 psi. Failure to use proper valve could result in an explosion, personal injury or property damage.
- ◆ Open the pressure relief valve at least annually to ensure waterways are clear. Avoid contact with the scalding water that will be released. Failure to open valve could result in an explosion if valve should stick.
- ◆ DO NOT install in home, basement or garage.
- ◆ Do not use petroleum-based cleaning or sealing compounds in the heating system. Pump and valve water seal deterioration will occur. This can result in substantial property damage.
- ◆ Do not use "homemade cures" or "boiler patent medicines". Serious damage to the appliance, personnel and/or property may result.
- ◆ To avoid electric shock, disconnect electrical supply before performing maintenance.
- ◆ To avoid severe burns, allow the appliance to cool before performing maintenance.
- ◆ This appliance requires electricity whenever in operation. Operation without electricity could result in the appliance overheating. If power outages are anticipated, a back-up electrical generator is recommended.
- ◆ Appliance Operation —
 - DO NOT block flow of combustion or ventilation air to the appliance.
 - DO NOT turn off the pump or prevent fluid flow during operation.
 - DO NOT restrict access to the rear of the unit for maintenance..

PRODUCT SPECIFICATIONS

MODEL	145	275	345
Height	46"	57 ½"	57 ½"
Length (with Fan)	58"	58"	73"
Width	30"	38 ½"	38 ½"
Fire Box Length	42"	42"	55 ½"
Fire Box Diameter	25"	32 ½"	32 ½"
Fire Box Volume	10 cubic Ft	17 cubic Ft	23 cubic Ft
Door Opening	16" x 20"	19 ½" x 25"	19 ½" x 25"
Water Volume	48 Gal	59 Gal	76 Gal
Chimney Size	6" Double Wall	6" Double Wall	6" Double Wall
Weight	630 lbs	900 lbs	1,050 lbs
Sustained Output	40,000 Btu/Hr	80,000 Btu/Hr	100,000 Btu/Hr

SHELTERED UNITS	S-145 SS	S-275 SS	S-345 SS
Height to Roof Peak	67"	67"	67"
Width	48"	48"	48"
Length	72"	72"	84"
Chimney Size	6" Double Wall	6" Double Wall	6" Double Wall
Weight	1,080 lbs	1,350 lbs.	1,590 lbs.

Note: Output values are based on theoretical 12 hour sustained burn rate under optimal conditions and are provided as guideline only. Actual output will depend on a variety of factors beyond the manufacturer's control, including: boiler location, wood species, wood moisture, wood size, ash management and combustion air temperature...to name a few.

PRODUCT DESCRIPTION

The Aqua-Therm is a wood burning boiler. It is to be installed in a building or shelter outside the structure being heated. It can also be purchased as a completely enclosed, sheltered unit. A circulating pump moves the heated water to a heat emitter. This can be baseboard radiator, finned radiator (heat exchanger), unit heater or radiant floor heating systems.

Installing the Aqua-Therm in a site built building allows additional space for storing wood, allowing it to dry properly. Also, the operator is protected from snow and rain while loading or maintaining the appliance. If the Aqua-Therm is to be installed in a building or shelter follow all instructions on pages 9-11.

The “Sheltered” Aqua-Therm requires minimal assembly. The weather tight enclosure, insulation blanket, wiring and controls come factory installed. Some near boiler plumbing is required. It is also recommended that the shelter be set on a concrete pad for stability and to keep clear from combustibles. **Never store combustibles or chainsaws in the shelter.**

The combustion process is controlled by an Aquastat that senses exiting water temperature. The Aquastat energizes a blower if water temperature is below setpoint (typically 165° F—180° F). Once the desired water temperature has been obtained, the Aquastat turns off the blower. If water temperature falls by a certain amount (called the “differential”) the Aquastat starts the process over again. It is not necessary to run a thermostat wire from the building being heated to the boiler.

The Aquastat simultaneously provides power to the blower and associated solenoid controlling a flapper mounted on the blower inlet. With the flapper opened, the blower moves air into the firebox below the grates and through the door. The blower and solenoid operate together to regulate air flow into the firebox. A High Temperature Safety will interrupt power to the blower and solenoid if temperature exceeds 190° F. It will automatically reset once temperature falls below 150° F.

A Loading Switch on the control panel interrupts power to the blower reducing the fire prior to opening the loading door.

A second, “Safety” latch on both the loading door and the ash door allow unburned gases to combust prior to opening the door. Always pause between the first latch and the safety latch to minimize flare backs.

The system is an open system. A fill cap will relieve pressure if it exceeds 18 psi. An expansion tank allows the water to expand or contract as it changes temperature while maintaining a fairly constant pressure. A pressure relief valve is installed on the appliance to safely reduce system pressure if it ever exceeds 30 psi. The appliance is hydrostatically tested at the factory to 60 psi.

The water/anti-freeze solution is continuously pumped through the appliance to the building being heated. The thermostat in the building being heated determines how the delivered heat is used.

Your Aqua-Therm warranty requires a minimum of 30% glycol in the system. Your Aqua-Therm comes with a glycol tester to aid you in determining your glycol percentage. Refer to the instruction sheet that was packed with your glycol tester. Anti-freeze Tester instructions are also provided on page 44.

Open System Tank

Some State Codes require that the unit be continuously vented to the atmosphere. In these cases, an Open System Tank is plumbed in place of the Fill Cap. The Tank has a sight glass for level indication and an open vent at the top. The Tank allows for water volume expansion as the system heats up, eliminating the need for the Expansion Tank, Air Scoop and Air Vent.

ECO-One Model

The Aqua-Therm ECO-One model has a second blower in the door and an upper baffle designed to increase combustion air and reduce emissions. Installation and operation of the ECO-One is identical to the traditional Aqua-Therm units.

Hot Water - Radiant Floor & Baseboard

The Aqua-Therm delivers hot water into the building and attaches to backup boiler or a bypass loop. The pump on the Aqua-Therm runs continuously.

A surface Aquastat is used as a safety limit Aquastat on hydronic systems. If the boiler temperature rises above the Aquastat setting the safety limit will bypass the house thermostat and shed excess heat.

Plumbing and Wiring diagrams - pages 32-33.

Forced Air

The Aqua-Therm delivers hot water into the building and attaches to a bypass loop. The pump on the Aqua-Therm runs continuously.

A wall thermostat in the space being heated controls a relay, which starts and stops the existing furnace fan. The circulating pump continuously circulates hot water throughout the entire system. Heat will be extracted when the existing furnace fan moves air through the heat exchanger.

A surface Aquastat is used as a safety limit on a forced air system. It is strapped to the hot supply pipe, usually in the house near the existing furnace and is set 10° higher than the fan control Aquastat on the Aqua-Therm. If the pipe it is strapped to reaches the setting, the strap-on Aquastat will override the thermostat and turn the fan of the existing furnace on to get rid of excess heat.

Plumbing and Wiring diagrams - pages 30-31.

INSTALLATION: TIPS

Avoiding Air Locks

The **AQUA-THERM** is designed to not exceed 18 psi, venting to the atmosphere if necessary. Water running downhill balances the force required to move water uphill. Air trapped in the lines prevents circulation. Poor water circulation is a common start up problem. Reduced flow can be difficult to detect because the pipes will feel hot. It is essential to provide a means for air in the lines to escape as the system is being filled. Design piping to avoid high points where air can be trapped or install bleed vents at these locations. Various vent fittings are available such as vented brass elbows or baseboard tees. Vents should be open during the fill process. Close the vents when bubble-free water runs out. The auto air vents on top of the air scoop should remain open at all times.

Ball Valves

Install ball valves in the lines to isolate various components or sections. The ball valves will eliminate the need to drain and refill the entire system should joints need to be re-soldered or plumbing modified. Normally, isolation pump flanges are supplied with the pump. These have built in ball valves that can be opened or closed with an Allen wrench. This allows the pump to be replaced without draining the system. It is recommended that isolation ball valves be installed in the home on each transfer line to assist in filling the system.

Water Supply

By adding a tee and an additional drain valve to the appliance line in your home, you can add water to the heating system from the basement. The **AQUA-THERM** should be filled the first time according to page 37. When adding water to system from basement, we suggest using a hose between boiler line and domestic water supply. Ensure that you can adequately monitor system pressure while filling. Ideally, system pressure should be visible from the valve being used to fill the system. When completed, disconnect water supply to prevent accidental filling or backflow, which may contaminate your domestic water.

Corrosion Inhibitor/Anti-freeze

It is required that a corrosion inhibitor be used and maintained in the **AQUA-THERM** to prolong the life of the appliance. **Failure to do so will result in loss of Warranty.** At a minimum, corrosion inhibitor level must be tested and adjusted annually. In addition to freeze protection, most hydronic anti-freeze solutions include an inhibitor package designed to reduce corrosion. Use either a corrosion inhibitor or anti-freeze specifically designed for hydronic (or boiler) systems. Follow all instructions for maintenance, most require annual testing and replenishment. Check instructions with anti-freeze for recommended dilution percentage. Follow all instructions for the selected anti-freeze, most require that the system be flushed prior to adding and that the water be within a certain Ph band.

Plumbing & Wiring

When plumbing and wiring, it is important to know which package you purchased (WO or FA). Check carefully to be sure you are using the proper instructions for your system. Note that the FA package requires purchasing the WO package as well.

Relief Valves

Place a 5-10 gallon bucket under the relief valve to catch the water or anti-freeze solution if the relief valve would open. See page 21 for details on piping the relief valves.

1" Fittings

If using non-metallic transfer lines, ensure that the fittings on both ends of the transfer lines are tight.

Heat Exchanger Positioning

If using a forced air heat exchanger, position your heat exchanger so air won't be trapped in the "U's". This usually means the tubes should be horizontal. The hot (supply) line from boiler should enter the bottom opening on the heat exchanger. Examine your components and visualize how the air will escape before you solder the connections. If possible, leave room to access the heat exchanger for cleaning. Dust collects on the fins reducing its ability to transfer heat.

INSTALLATION: PLACEMENT

NOTE

CHECK WITH INSURANCE COMPANY PRIOR TO INSTALLATION. IT IS THE OWNER'S RESPONSIBILITY TO ENSURE THAT THE APPLIANCE IS ACCEPTABLE TO THEIR INSURANCE CARRIER.

NOTE

VERIFY ALL LOCAL CODES AND ORDINANCES PRIOR TO INSTALLATION. IT IS THE OWNER'S RESPONSIBILITY TO ENSURE THAT THE APPLIANCE MEETS ALL LOCAL CODES AND ORDINANCES

NOTE

LOCAL CODE OR ORDINANCE PLACEMENT REQUIREMENTS TAKE PRECEDENCE AND MUST BE OBSERVED

NOTE

Improper use or failure to maintain the outdoor wood boiler may cause nuisance conditions. Persons operating this outdoor wood boiler are responsible for operation of the outdoor wood boiler so as not to cause nuisance conditions. Even proper use and maintenance of the outdoor wood boiler, and meeting the distance and stack height recommendations and requirements in State and local regulations may not always be adequate to prevent nuisance conditions in some areas due to terrain or other factors.

- 1) When placing the **AQUA-THERM**, the following should be considered:
 - A) Review the minimum clearances to combustibles on pages 10- 11.
 - B) Review the recommended stack heights on page 18.
 - C) Do not locate near any combustible materials, gasoline or other flammable liquids or gases.
 - D) Locate away from dry grassy areas.
 - E) Place far enough away from any building to minimize fire danger.
 - F) Check with insurance company and local codes or ordinances.
 - G) Do not install in an area where nearby structures or trees might cause down drafts.
 - H) Typically Outdoor Wood Burning Appliances are located 40 to 100 ft down wind from the served structure.
 - I) Do not locate an Outdoor Wood Burning Appliance within 100 ft of a residence not served by the appliance. Be considerate of neighboring residences, properties, parks, etc.
 - J) Transfer lines in excess of 100 ft may require a larger size pump than the one provided with the appliance.
 - K) Locate to allow easy access to wood supply.
 - L) To aid in smoke dispersal, extra chimney lengths may be required depending on the distance to surrounding structures. See page 18 for guidance.
 - M) It is recommended that the appliance be located with due consideration to the prevailing wind direction.
 - N) It is recommended that the appliance be located with due consideration to any neighboring residences.
 - O) The unit requires 115 V 15 Amp electrical service to operate.
 - P) Locate the unit to provide access to wood supply. Wood should be split, stacked and seasoned for one year prior to use. Wood should not be stored within the minimum clearance to combustibles stated on page 10. Ensure that wood storage does not impede maintenance access to the sides or back of the appliance.

DANGER

Failure to keep **AQUA-THERM** area clear and free of combustible materials, gasoline and other flammable liquids and vapors can result in severe personal injury, death or substantial property damage.

INSTALLATION: CLEARANCES

ECO-One Models:
Add 8" to the length for
the door mounted blower

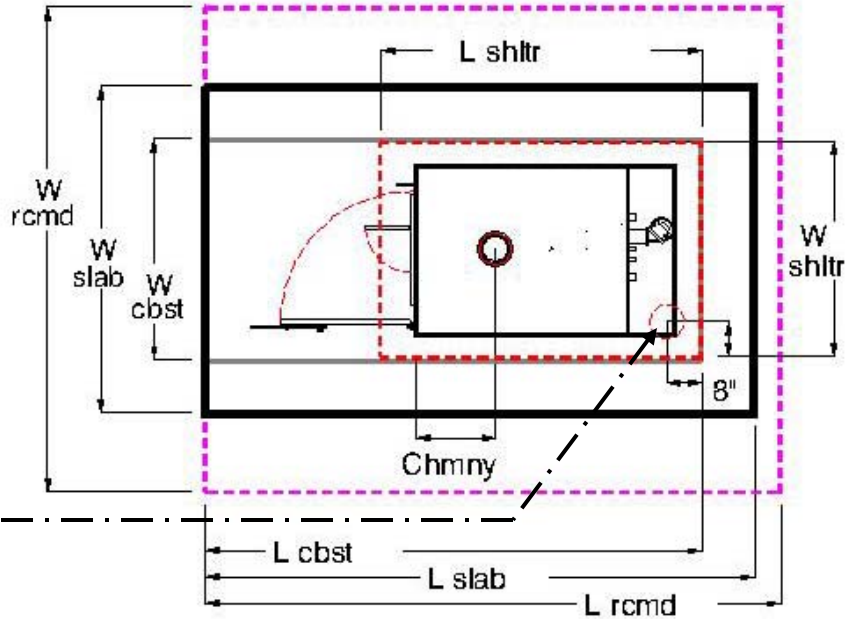

Sheltered Units:
Recommended Transfer
Line opening

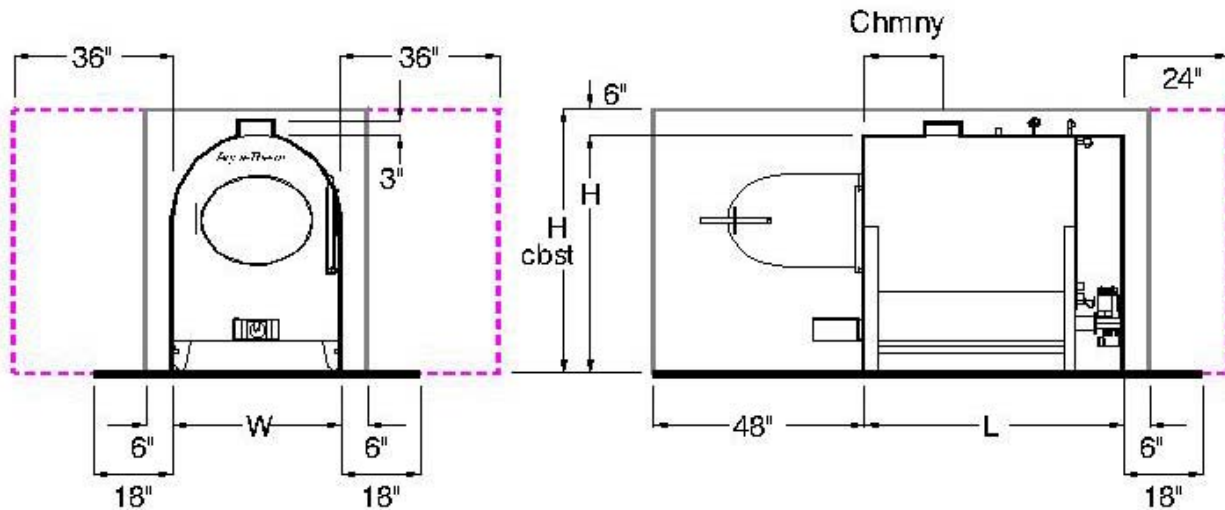

	APPLIANCE DIMENSIONS			SLAB DIMENSIONS (MINIMUM)		BUILDING DIMENSIONS (INTERIOR)				CHIMNEY	SHELTER DIMENSIONS	
						Minimum based on Combustibles		Recommended				
	L	W	H	L	W	L cbst	W cbst	L rcmd	W rcmd		L shltr	W shltr
145	58"	30"	46"	124"	66"	112"	42"	132"	102"	18"	72"	48"
275	58"	38 1/2"	57 1/2"	124"	74 1/2"	112"	50 1/2"	132"	110 1/2"	18"	72"	48"
345	73"	38 1/2"	57 1/2"	139"	74 1/2"	127"	50 1/2"	132"	110 1/2"	18"	84"	48"

INSTALLATION: SITE PREPARATION

Outdoor Wood Burning Appliances shall not be installed in a location where gasoline or other flammable vapors are likely to be present. The **AQUA-THERM** is designed to be installed away from the building being heated either as a stand alone unit or in a separate structure. All installations must be in accordance with local and state codes which may differ from this manual.

Foundation

The **AQUA-THERM** should be located on a level 2” minimum thickness concrete foundation pad. At a minimum, there must be a non-combustible pad (concrete, brick or paver) the width of the appliance extending out 48 inches from the front of the unit.

DANGER

A non-combustible pad must be installed in front of the unit to contain any sparks or coals out of the Loading door or Ash door. Fire can result, causing severe personal injury, death or substantial property damage.

DO NOT install in a basement or garage.

Flooring

The **AQUA-THERM** should be placed on a non-combustible floor which must extend a minimum of 6 inches beyond the appliance on both sides and back and 48 inches in front.

DANGER

Do not install appliance on carpeting even if foundation is used. Fire can result, causing severe personal injury, death or substantial property damage.

Clearances:

The **AQUA-THERM** must be installed with these minimum clearances from combustibles.

Top – 24” Front – 48” Back – 6” Sides – 6”

DANGER

All single wall chimneys must be at least 18” from any combustible surface. Fire can result, causing severe personal injury, death or substantial property damage.

The following clearances are recommended for maintenance:

Back – 24” Sides – 36”

INSTALLATION: TRANSFER LINES

Pipe Fittings: When using Pex-Aluminum-Pex tubing between the structure and the appliance, remember to use a beveling tool to bevel the inside edge of the tubing. Beveling will reduce chance of damaging the O-rings on the fittings.

It is recommended that Isolation Valves be located on each transfer line at the structure being served. This will assist in initial filling of the system.

Pipe: PEX-Aluminum-PEX, PEX with an EVOH oxygen barrier, or Soft temper copper in a roll (type L or type K) may be used to conduct water from the appliance to the structure. Minimum pipe rating should be 180°F at 50 psi. Purchase in full lengths to avoid joints underground. Inside the house a rigid copper Type M or PEX with an oxygen barrier are most commonly used.

The pipe size needed depends upon the distance between the Aqua-Therm and the heat exchanger. Diameters that are too small will restrict water flow reducing the amount of heat available to the house. Use a minimum of 1" I.D. pipe regardless of the distance. Situations where the underground lines are more than 100 feet in one direction may require a larger pump than that provided. Contact your **AQUA-THERM** representative for assistance in sizing the appropriate pump.

The underground pipe and insulation are usually buried 18" to 24" deep. A 3' depth is recommended for under driveways. To go deeper can increase the chances of laying the pipes where ground water could rob heat.

Pipe Insulation: The underground pipe insulation is the key to an efficient heating system. Without proper insulation excessive heat will be lost to the ground. Insulation must not absorb water. Sheets of 2" blue or pink closed cell Styrofoam can be cut into strips with a table saw or circle saw. One 4' x 8' sheet can be cut into 4 - 8" strips, 4 - 1 1/2" strips and 2 - 1" strips. Each sheet will insulate 16 feet of pipe. Assemble the strips to "box" the water pipes. The first top section should be cut in half so the top and bottom seams are off set. The insulation can be held together with nails, tape or glue. By wrapping a layer of 6 mil. plastic over the box before back filling to prevent surface water from intruding. Typically this style of insulating achieves an R-10.

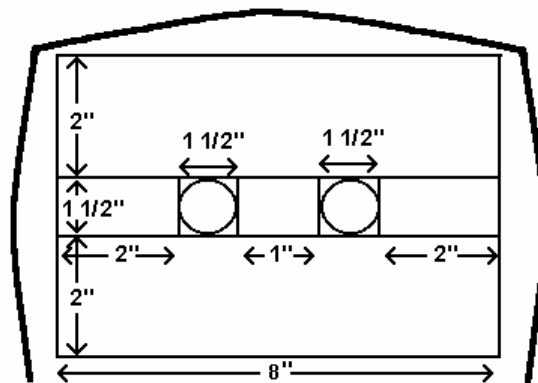

We have tested 100 ft. runs in Minnesota and have less than 2° temperature loss with this system. If insulated properly there will be minimal heat loss from the pipes. There is no need to bury below frost line. Eighteen inches is deep enough except where there is vehicular traffic, then bury lines 36 inches.

INSTALLATION: TRANSFER LINES (Cont.)

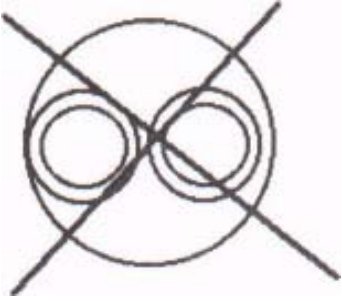

Some customers have used foam pipe insulation on the lines; then placed them in a 4" sewer pipe. This style of insulation has an R-value of 2. This is not enough insulation! We have tested this system and found 10-20° heat loss on 50 ft. runs. A 20° loss can rob 40 - 50,000 BTU's per hour. This is enough to heat many homes! No one can afford this type of heat loss into the ground.

NOTE:

A wire, going to the house thermostat, is NOT needed in trench, however a 115-volt wire for power can be added.

Preformed Insulation:

Aqua-Therm offers two types of preformed pipe insulation.

Insul-PEX

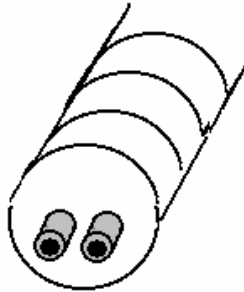

Insul-PEX is a prefabricated transfer conduit containing two 1" PEX lines and insulation encased in a plastic water tight, corrugated tube. Ensure that PEX fittings are used with Insul-PEX pipe.

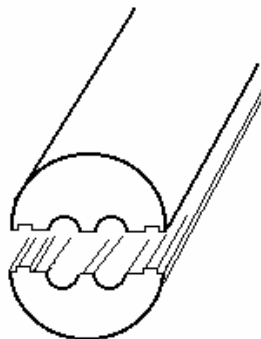

Round

For heavy soil or areas where ground water may be a problem, use the round design insulation. This is specially made to fit inside a 6" PVC. Slip insulation inside pipe to make a waterproof installation.* Round insulation is made of Type II Polystyrene. It's important to keep water out of the pipe when it's being installed.

* Gluing seams and joints is recommended.

INSTALLATION: LIFTING THE AQUA-THERM

HANDLING & PLACEMMENT OF THE APPLIANCE

DANGER

Ensure that all lifting devices, chains, etc. Be rated for the weight being lifted. Use caution when lifting the **AQUA-THERM**. Dropping of the appliance can cause severe personal injury, death or substantial property damage.

1. The **AQUA-THERM** can be moved by forklift from the sides. Do not fork from the front or back. The appliance can also be lifted from the top using a chain attached to the lifting bars on the top front and top back of the appliance. If lifting from the top:
 - It is recommended that the chain have lifting hooks on the ends.
 - It is recommended that some sort of spreader bar (or the bucket on the loader) be employed to protect the jacket from damage by the chains.
 - Lift **SLOWLY** to verify balance point prior to moving.
2. The Sheltered **AQUA-THERM** can be moved by forklift through special openings on the front of the shelter. Do not fork from the sides or back. It can also be lifted from the top by attaching a chain to the lift hook located on the roof near the chimney
3. The appliance should be placed on a concrete slab. Level the unit to allow free opening and closing of doors. See page 10 for slab dimensions. For Sheltered **AQUA-THERM** review the recommended Transfer Line opening on page 10 (8" off of the right rear corner of the shelter).

INSTALLATION: INSPECTING CONTENTS

COMPONENTS SHIPPED LOOSE INSIDE: (see page 48 for component illustrations)

Unsheltered AQUA-THERM

- Expansion Tank
- Air Scoop and Air Vent
- Aquastat and Well
- Pressure and Temperature Gauge
- Blower and Shutter Assembly
- Wiring Harness
- Pump and Flanges
- Relief Valves (Temperature/Pressure and Pressure)
- Ash Auger Crank
- Ash Door
- Insulation Blanket, Foil Tape
- Surface Aquastat
- Plumbing parts: 1-1/4" Elbow, Nipple, 2 Boiler Drain Valves
- Open System Tank (if used)

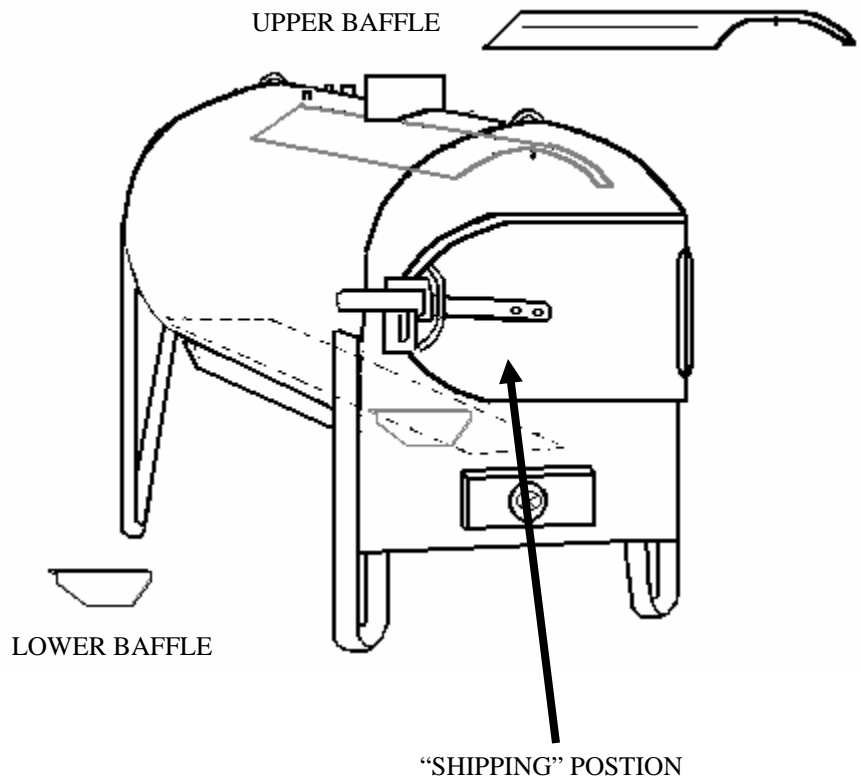

Sheltered AQUA-THERM

- Expansion Tank
- Air Scoop and Air Vent
- Ash Auger Crank
- Surface Aquastat

Additionally, if the Forced Air package (FA) is ordered, there will be a Fan Control Relay and a Water to Air Heat Exchanger ("Coil").

BAFFLES

The Baffles (Upper and Lower) come factory installed in all units. Inside the Fire Box, verify that the Lower Baffle is in place below the Grates and that the Upper Baffle is in place below the chimney opening.

LOADING DOOR HANDLE

The AQUA-THERM comes with the Loading Door Handle in the "shipping position". Remove the nut and move the Handle to the outer hole for proper operation. Reinstall the nut.

GRATES

The unit comes with grates installed. Grates should be placed so that the side with the "wider" opening is facing down to prevent coals from clogging openings and restricting airflow.

ASH DOOR:

The door is normally shipped unattached to avoid damage. Install door before lighting a fire. Stove will overheat without ash door properly in place and sealing. Check to be sure door closes securely and that gasket is sealing.

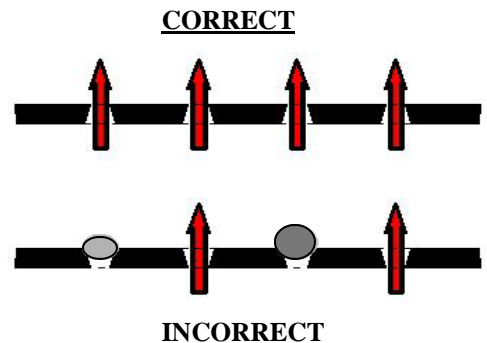

INSTALLATION: INSULATION BLANKET

(UNSHELTERED UNITS ONLY)

MODELS 145 SS AND 275 SS

Required Tools: Scissors, Utility Knife and Masking Tape

CAUTION

Fiberglass may cause minor skin irritation so we recommend that you wear gloves and long sleeve shirt. Wash with soap and water when finished.

NOTICE

Insulation must be installed properly to ensure maximum R-value. Do not stretch tight, but leave fluffy.

1. Clean appliance surfaces with soap and water to ensure tape will adhere properly. Dry completely.
2. Locate the piece of insulation for the back (145: pc 40135, 275: pc 40136). Cut a circular piece to adequately cover the back of the appliance (approximately 8" larger than the diameter of the back).
3. Install back piece on back of the appliance, foil side out. Cut slits to accommodate pipe openings (pay careful attention to relief valve opening at the top). Hold in place with masking tape.
4. If controls and chimney have already been installed, slit the insulation sheet down the middle starting from the back to the chimney opening. If controls are not installed, go to step 5.
5. Wrap insulation around the appliance (145: pc 40139, 275: pc 40140). Carefully cut circles around fittings where controls are to be attached. Use foil tape to close slits between openings on top of the appliance if necessary.
6. Attach the sides together at the bottom of the Ash Trough with foil tape the full length of the appliance.
7. Seal around chimney opening with foil tape.
8. Attach the body insulation to the back insulation with foil tape. Tape completely around stove.
9. On front of appliance fold facing and tuck under insulation to form a finished edge.

DANGER

Ensure that the pressure relief valve or the temperature relief valves are not obstructed. Failure to comply can result in personal injury, death or substantial property damage.

INSTALLATION: INSULATION BLANKET

(UNSHELTERED UNITS ONLY)

MODELS 345 SS

Required Tools: Scissors, Utility Knife and Masking Tape

CAUTION

Fiberglass may cause minor skin irritation so we recommend that you wear gloves and long sleeve shirt. Wash with soap and water when finished.

NOTICE

Insulation must be installed properly to ensure maximum R-value. Do not stretch tight, but leave fluffy.

1. Clean appliance surfaces with soap and water to ensure tape will adhere properly. Dry completely.
2. Locate the piece of insulation for the back (pc 40136). Cut a circular piece to adequately cover the back of the appliance (approximately 8" larger than the diameter of the back).
3. Install back piece on back of the appliance, foil side out. Cut slits to accommodate pipe openings (pay careful attention to relief valve opening at the top). Hold in place with masking tape.
4. There are 3 pieces for the sides and bottom, all labeled 40138. Attach the first piece with masking tape to the side of the appliance foil side out.
5. Attach the second piece with masking tape to the other side of the appliance foil side out. Overlap foil flap to the first piece. Run a piece of foil tape along the seam at the top.
6. Attach the third piece with foil tape to the second piece running the length of the bottom of the appliance.
7. Wrap the bottom piece underneath the appliance, fitting around legs. The first side piece should overlap the bottom piece by about 2". Attach the bottom and side pieces with foil tape running the length of the appliance.
8. Finish by taping over all seams with foil tape.
9. Seal around chimney opening with foil tape.
10. Attach the body insulation to the back insulation with foil tape. Tape completely around stove.
11. On front of appliance fold facing and tuck under insulation to form a finished edge.

DANGER

Ensure that the pressure relief valve or the temperature relief valves are not obstructed. Failure to comply can result in personal injury, death or substantial property damage.

INSTALLATION: VENTING

DANGER

All single wall chimneys must be at least 18” from any combustible surface. Fire can result, causing severe personal injury, death or substantial property damage.

Chimney Material:

A 6” listed type “HT” double wall chimney approved for temperatures up to 1400 °F is required.

On Unsheltered units, the Chimney Ring is sized to accept the Female (socket) end of the chimney.

Chimney Connectors: Connectors shall be installed to join the appliance to the vertical chimney unless the chimney is attached direct. Use 6” listed type “HT” double wall chimneys or approved connectors. When installing, keep the connector as straight and short as possible. Assemble in accordance with the vent manufacturers instructions. Additional sections may be required to clear the peak of the structure. Do not install more than one appliance per flue.

DANGER

Do not install more than one appliance per flue. Flue gas spillage and carbon monoxide emissions can occur causing server personal injury or death.

Chimney Height: To prevent downdrafts, chimney or vent without a listed cap should extend at least 3 feet above the highest point where it passes through a roof and at least 2 feet higher than any portion of a building within a horizontal distance of 10 feet. A chimney or vent must not extend less than the distances stated above. Check local codes or ordinances for additional requirements. In general:

- Do not locate within 100 feet of any residence not served by the appliance.
- If located between 100 to 300 feet to any residence, it is recommended that the stack be at least 2 feet higher than the peak line of that residence.
- Nearby structures, trees or hills can cause downdraft conditions which force smoke to the ground. Chimney height may have to be raised to overcome downdraft conditions.

NOTE

Improper use or failure to maintain the outdoor wood boiler may cause nuisance conditions. Persons operating this outdoor wood boiler are responsible for operation of the outdoor wood boiler so as not to cause nuisance conditions. Even proper use and maintenance of the outdoor wood boiler, and meeting the distance and stack height recommendations and requirements in State and local regulations may not always be adequate to prevent nuisance conditions in some areas due to terrain or other factors.

ALL SOLID FUEL APPLIANCES CREATE VISIBLE SMOKE DURING SOME OPERATING CONDITIONS

BE CONSIDERATE OF NEIGHBORING HOUSES

INSTALLATION: TAPPING DIAGRAM

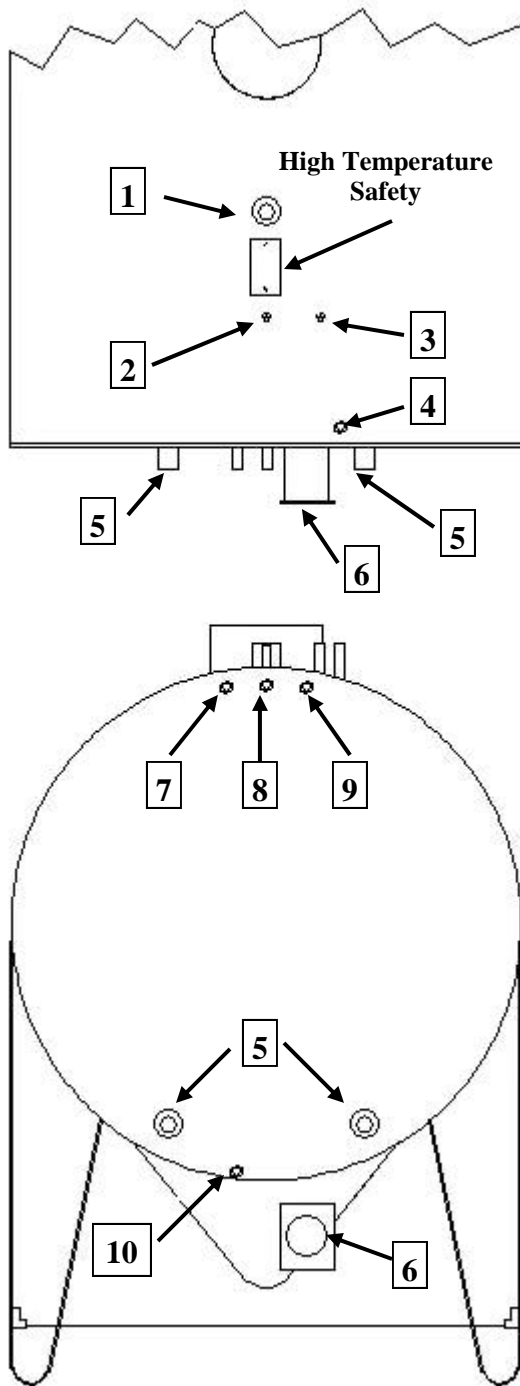

BUNG	SIZE	USE
1	1 1/4" F NPT	HOT Supply Line (345 has two)
2	1/2" F NPT	Well for Digital Aquastat sensor
3	1/2" F NPT	Pressure & Temperature Gauge
4	3/4" F NPT	Pressure Relief Valve Watts M335: 30 psi
5	1 1/4" F NPT *	COLD Return Line (275 & 345 have two)
6		Fan and Shutter Assembly
7	3/4" F NPT	Alternate location of Low Water Cut Off (if used)
8	3/4" F NPT	Temperature Relief Valve Cash Acme: 210°F, 80 psi
9	3/4" F NPT	Anode Rod
10	3/4" F NPT	Boiler Drain Valve
	3/4" M NPT	Boiler Drain Valve (Sheltered Units)

* **NOTE:** On some units the COLD Return connections (5) are 1" F NPT.

Fan Mounting Mount Fan/Shutter Assembly to the appliance. Ensure that the gasket seals tightly between the blower and the appliance flange.

WARNING

Failure to mount fan properly will result in boiler overheating.

INSTALLATION: PLUMBING

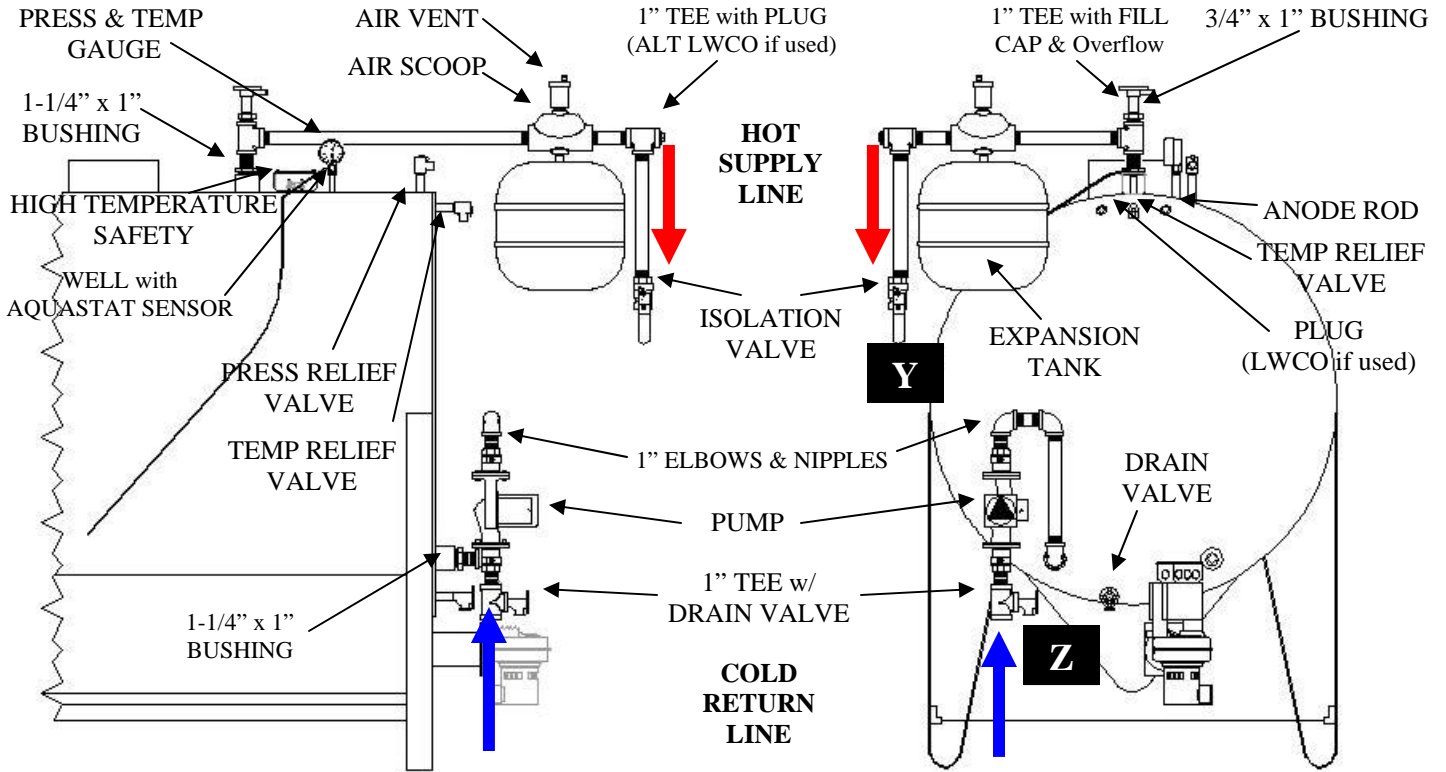

Standard Installation

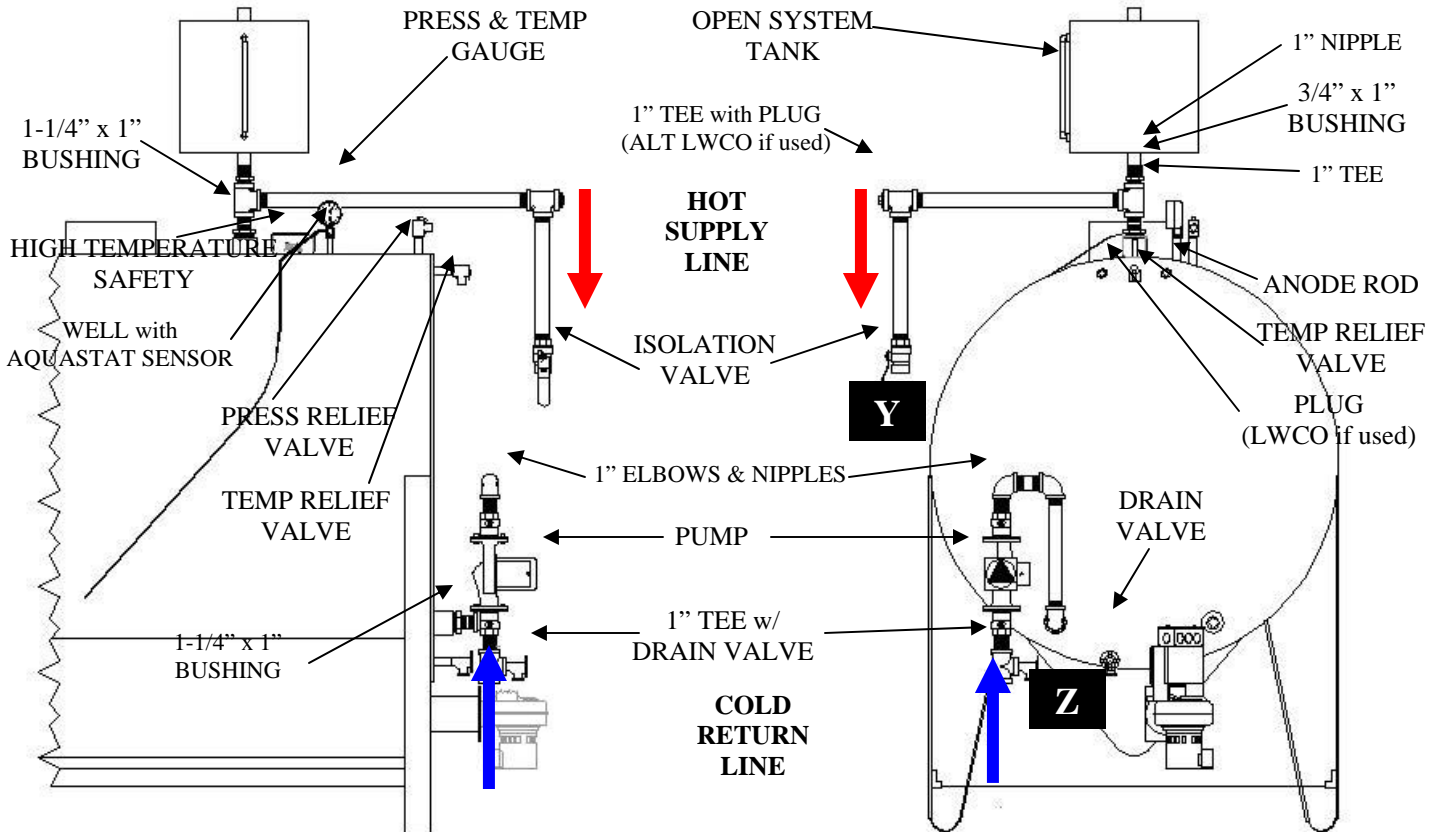

Alternative Installation with Opens System Tank (Required by some State and Local Codes).

General Plumbing: Install near boiler plumbing as suggested above. An Overflow Line should be attached to the Fill Cap and routed to a 5 to 10 gallon pail. The Pump, Air Vent, Air Scoop and Expansion Tank can be mounted either as shown or in the structure being heated.

Automatic Fill Valves:

An automatic fill valve is not recommended, if fill pressure is above 18 psi, the automatic fill valve would continuously dump water out the Fill Cap diluting the anti-freeze. In some situations all the anti-freeze could be lost. It is also more difficult to recognize a leak in a system with a valve continuously making up lost water. If an auto fill valve is installed, it is recommended that it be isolated once the system is filled and that fill pressure be set below 18 psi.

WARNING

If a feed water line and valve for adding water are incorporated, a backflow preventer is required to preclude heating system water from entering the domestic system.

Transfer Line Connections:

The Transfer Lines connect at the rear of the appliance at “Y” and “Z” per the diagram above. Use connectors appropriate for the Transfer Line being installed. The Hot Line (Supply Line) connects to “Y” and the Cold Line (Return Line) connects to “Z”. When using Pex-Aluminum-Pex tubing for transfer lines, remember to use the beveling tool or a pocketknife to bevel the end of the tubing. Beveling will reduce chance of damaging the O-rings on the fittings.

Multiple Buildings

If serving multiple buildings, install TEE’s to “Y” and “Z” (see previous page) or (275 & 345) use the additional 1-1/4” bungs. The AQUA-THERM requires continuous flow when in operation. If serving multiple buildings, ensure that at least one has continuous flow.

Relief Valve:

DANGER

Before filling the system, ensure the pressure relief valve is installed. Use only a boiler relief valve set to limit pressure to 30 psi. **Failure to comply** with these guidelines could result in failure of the relief valve to operate, resulting in possibility of severe personal injury, death or substantial property damage.

To avoid water damage or scalding due to relief valve operation:

- Discharge line must be connected to relief valve outlet and **run to a safe place of disposal**. Terminate the discharge line to eliminate possibility of severe burns should the valve discharge.
- Discharge line must be as short as possible and be the **same dimension as the valve discharge connection** throughout its entire length.
- Discharge line must **pitch downward** from the valve and terminate at least 6" above the floor drain where any discharge will be clearly visible.
- The discharge line shall **terminate plain, not threaded**, with a material serviceable for temperatures of 200°F or greater (copper, black pipe, galvanized or Pex-Al-Pex).
- **Do not pipe the discharge to any place where freezing could occur. Place a 5-10 gallon pail beneath discharge piping to catch any anti-freeze should the relief valve lift. Ensure that the discharge line ends at least 6 inches above the top of the bucket to prevent freezing.**
- **No shutoff valve** shall be installed between the relief valve and boiler, or in the discharge line. Do not plug or place any obstruction in the discharge line.
- **Test the operation of the valve** after filling and pressurizing system by lifting the lever. Ensure the valve discharges freely. If the valve fails to operate correctly, replace it with a new relief valve.

Low Water Cut Off (if required)

Some State and Local Codes and some Insurance Companies require a Low Water Cut Off device (LWCO) when the heat source is installed above radiation. If required, the LWCO must be installed at a high point in the system, in a Tee near the top of the boiler.

INSTALLATION: ELECTRICALS

BASIC ELECTRICALS

For your safety, **turn off electrical power supply at service entrance panel before making any electrical connections** to avoid possible electric shock hazard. Failure to do so can cause severe personal injury or death.

WARNING

Ensure power is shut off while making connections. Failure to do so may result in severe personal injury or death.

The pump can be located either in the structure being heated or on the appliance.

NOTICE

To ensure that the appliance always has flow when operating, it is recommended that the pump and the appliance receive power from the same breaker. This is most important if the pump is located remote from the appliance in the structure being heated.

WARNING

DO NOT apply power to the pump (located either in the heated structure or at the appliance) until system has been filled. The pump is water lubricated and must never be run dry.

Electrical installation must comply with:

1. National Electrical Code and any other national, state, provincial or local codes or regulations.
2. In Canada, CSA C22.1 Canadian Electrical Code Part 1, and any local codes.

Appliance must be **electrically grounded** as required by National Electrical Code ANSI/NFPA 70–latest edition. Ensure **ground wiring** is installed per wiring diagram. Good grounding is extremely important for proper operation.

SHELTERED UNIT

- Bring 110-volt power supply to the safety switch box (located just inside the back panel on the upper right).
- Use 12-2 or 14-2 UF wire with ground.
- Attach the power supply through the top of the box by installing a cable connector.
- Connect the black wire from power supply to one of the main lugs at the top of the box. There is a factory installed jumper to the bottom of the other breaker. The first breaker acts as a “Main” breaker and the second as a redundant breaker.
- The white wire from power supply is connected to one screw on the aluminum bar at the side of breaker.
- The ground wire from the power supply is connected to the remaining screw on the aluminum bar.

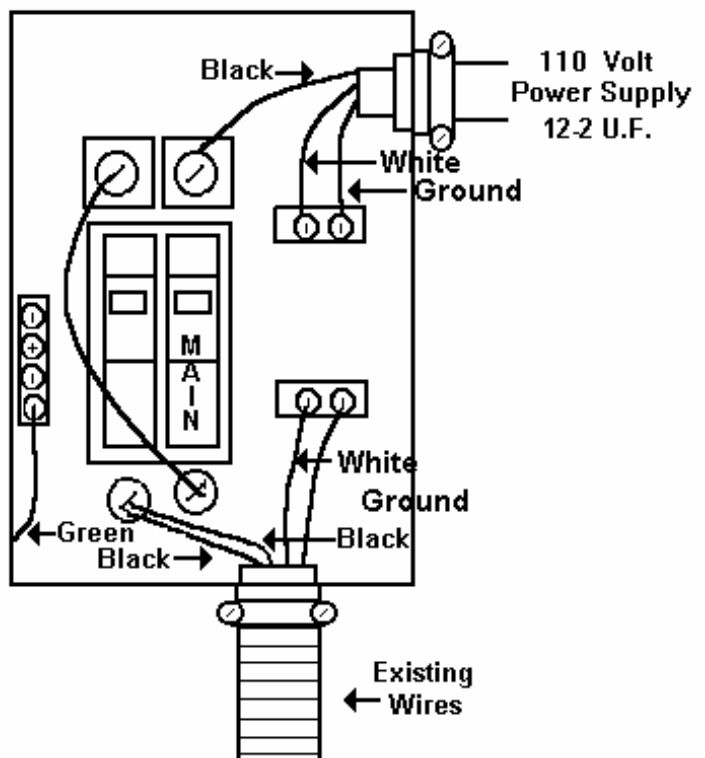

INSTALLATION: ELECTRICALS (Cont.)

UN-SHELTERED UNIT

1. Bolt wiring harness junction box to angle iron next to loading door hinge on stove.
2. Connect High Temp Safety Limit. (Use conduit with red and blue wire)
 - a. Open Safety Limit junction box cover on top of the Stove.
 - b. Connect red wire to one .
 - c. Connect blue wire to the other terminal.
 - d. Replace junction box cover.

3. Connect the Fan/Solenoid Harness.

(The ECO-One there are two identical Fan/Solenoid harnesses. Route the shorter one to the front Fan junction box and the longer harness to the back Fan junction box.)

Connect fan/solenoid using conduit with red, white and green wire. Solenoid has two black wires, it does not matter which is used.

- a. Open fan/solenoid junction box cover.
 - b. Remove one knockout and fasten conduit to the fan/solenoid junction box.
 - c. Connect red wire to one black for solenoid and red wire for fan.
 - d. Connect white wire to one black for solenoid and white wire for fan.
 - e. Connect green wire to the fan /solenoid junction box.
4. Connect main power from source in building to wiring harness junction box.
 - a. Open main junction box cover of harness.
 - b. Remove lower left knock out and fasten wire to main junction box.
 - c. Connect main power black to the pump switch screw terminal.
 - d. Connect main power white to the other whites in main junction box.
 - e. Connect main power green to main junction box and other greens in the main junction box.

5. Place the Digital Aquastat Sensor in the sensor well.

6. Place wire nuts on the black and white wires on the pump harness. **DO NOT CONNECT THE PUMP AT THIS TIME.** Power up the appliance and place the Master Switch to “ON”. The Digital Aquastat should light. Set up the Digital Aquastat following the procedure on page 26. Once the Aquastat is set, turn off power to the Appliance.

NOTE: The Pump will operate when the Master Switch is in the “ON” position. Operating the pump without water in the system will damage the pump.

7. Connect pump using conduit with black, white and green wire. Pump has two white wires, it does not matter which is used.

NOTE: Grundfos pumps have “push” type connectors. Connect the black wire to the “L” and the white wire to the “N”.

- a. Open pump junction box cover.
- b. Remove one knockout and fasten conduit to pump junction box.
- c. Connect black wire to one white wire on pump.
- d. Connect white wire to one white wire on pump.
- e. Connect green wire to pump green screw in pump junction box.

INSTALLATION: SETTING THE ANALOG AQUASTAT

NOTICE

Some Aqua-Therm units come with Analog Aquastats and some come with Digital Aquastats. Refer to the correct page for the model being installed.

Analog Immersion Aquastat:

1. Install the Aquastat well into bung on top of the stove (or into Supply piping). Ensure that it is tight enough to prevent leakage. **Do NOT tighten after controller is secured to well. Do NOT apply force to case.**
2. Loosen screw at top of case and remove cover. The white dial inside should be set to 10°, this is the Temperature Differential.
3. Loosen 2 screws at lower bottom back. Turn angled plate so that sensing element opening is at the bottom of Aquastat. Carefully route sensing element through hole. Sharp bends in sensing element wire could impair operation. Now Aquastat will be vertical when installed.
4. Insert the sensing element into the immersion well. The sensing element **MUST** touch the bottom of the well.
5. Fasten Aquastat to the well with the adapter clamp on bottom of unit. Ensure the clamp is properly positioned over the groove of the well. Also, ensure the flange at the opening of the well fits snugly into the opening of the case.
7. Replace cover.

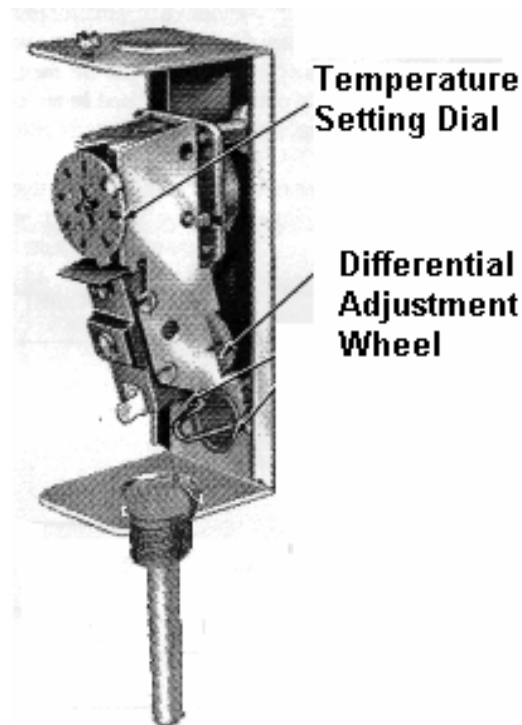

ADDITIONAL SAFETY CONTROLS

High Temperature Limit Control (if required): If installation is to comply with ASME or Canadian requirements, an additional **high temperature limit** is required. Install control in supply piping close to the appliance. Set second control to minimum 20 °F above setpoint of first control. Maximum allowable setpoint is 240 °F.

Low Water Cutoff (if required): A **low water cutoff device (LWCO)** is required when the heat source is installed above radiation level or by certain state or local codes or insurance companies. If required, the LWCO must be installed .

SCHEMATIC WIRING DIAGRAM

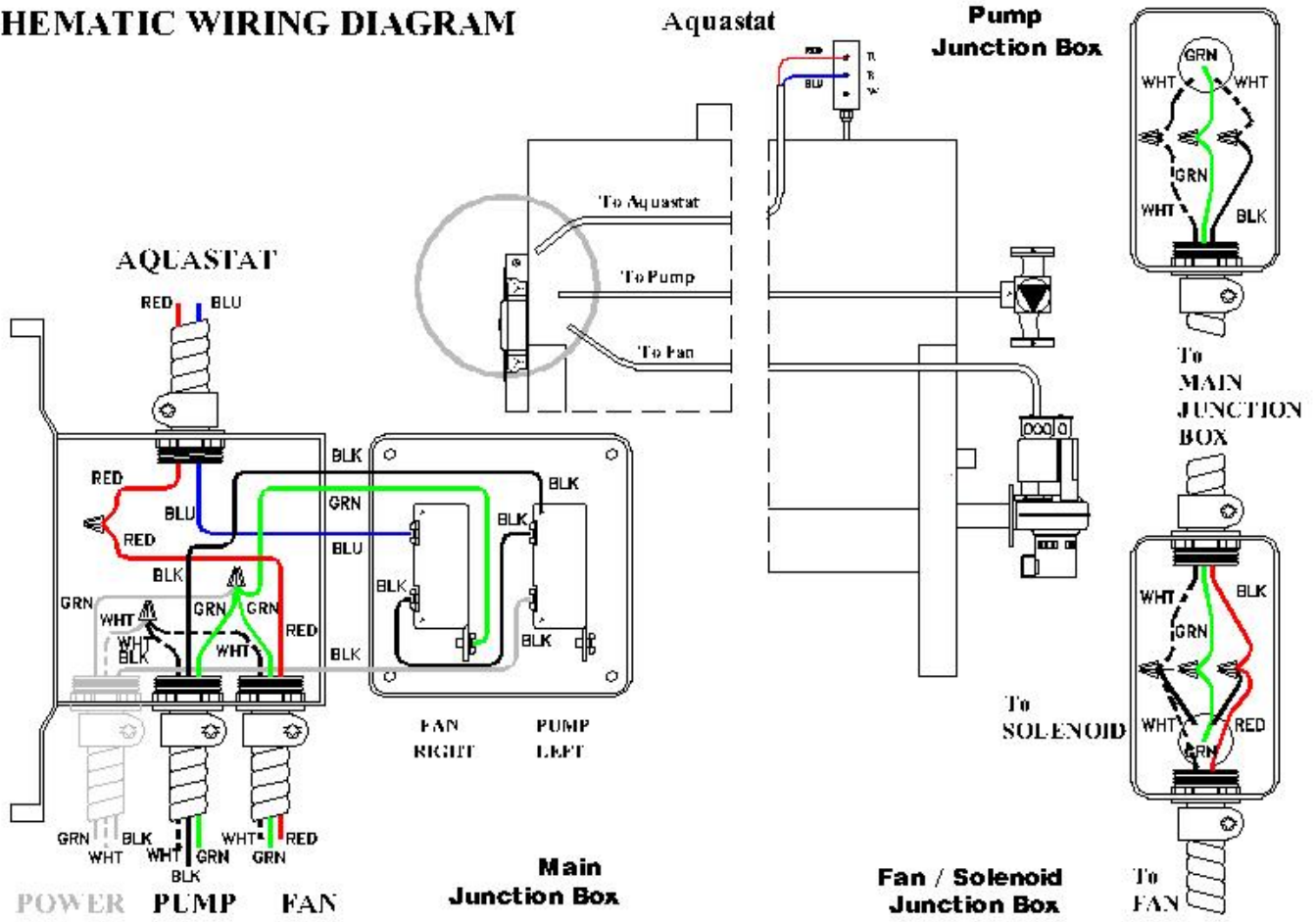

LADDER WIRING DIAGRAM

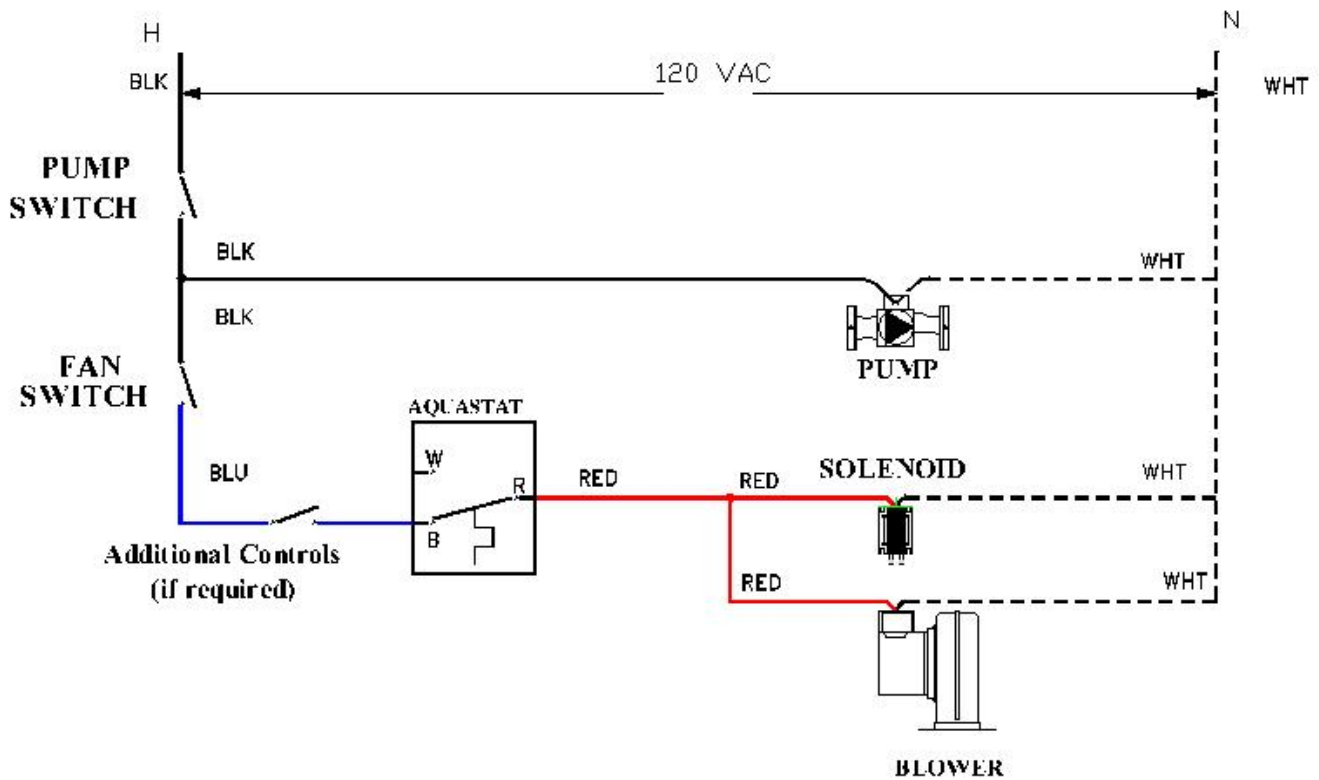

INSTALLATION: SETTING THE DIGITAL AQUASTAT

NOTICE

For troubleshooting or specific questions, refer to the Aquastat instructions packaged in the Literature folder.

NOTICE

The Aquastat does not come preprogrammed from the factory and must be set up at the jobsite.

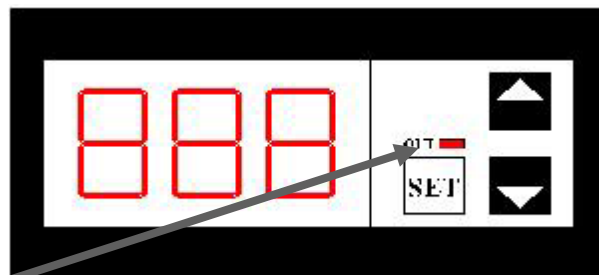

“Out” Light indicates that the Aquastat is sending power to the Blower

1.) Programming Initial Parameters:

- A.) To enter Programming Mode; Press and Hold **SET** for 8 seconds. The access code “00” will be displayed.
- B.) Press **SET** to acknowledge the access code, “SP” will be displayed.
- C.) Press **UP** arrow until “r0” is displayed This is the Temperature Offset.
- D.) Press **SET** to view the value, press **UP** arrow until value reads “5”, then press **SET** to accept the new value.
- E.) Press **UP** arrow until “r2” is displayed. This is the Max Aquastat Setting.
- F.) Press **SET** to view the value, press **UP** arrow until value reads “180”, then press **SET** to accept the new value.
- G.) Press **UP** arrow until “d0” is displayed. This is the Aquastat Mode (Heating or Cooling).
- H.) Press **SET** to view the value, press **UP** arrow until value reads “Ht”, then press **SET** to accept the new value.
- I.) Press **UP** arrow until “t0” is displayed Note: the letter “t” appears as an upside down “F”. This is the Max Temperature that the Aquastat will display.
- J.) Press **SET** to view the value, press **UP** arrow until value reads “250”, then press **SET** to accept the new value.
- K.) Press **SET** and **DOWN** at the same time to exit Programming Mode or wait one minute and the display will automatically exit.

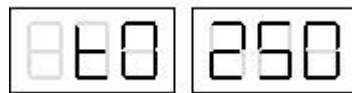
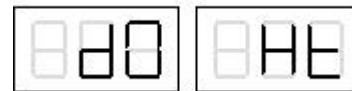

***** **IMPORTANT: COMPLETE STEP 2 FOR PROPER OPERATION!** *****

2.) Entering desired Temperature:

NOTICE

Set Point (SP) is the only parameter the user can access without entering Programming Mode.

- A.) Press **SET** until “SP” appears on the display.
- B.) Press **SET** again. The set point temperature is shown on the display.
- C.) Press **UP** or **DOWN** arrows to desired temperature.



It is recommended to set the Aquastat at 160°F. If the House Thermostat will not reach temperature, the Aquastat can be adjusted up to 180°F.

- D.) Press **SET** again to accept the new value. “SP” appears on the display.
- E.) Press **SET** and **DOWN** at the same time to exit or wait one minute and the display will automatically exit.

SCHEMATIC WIRING DIAGRAM

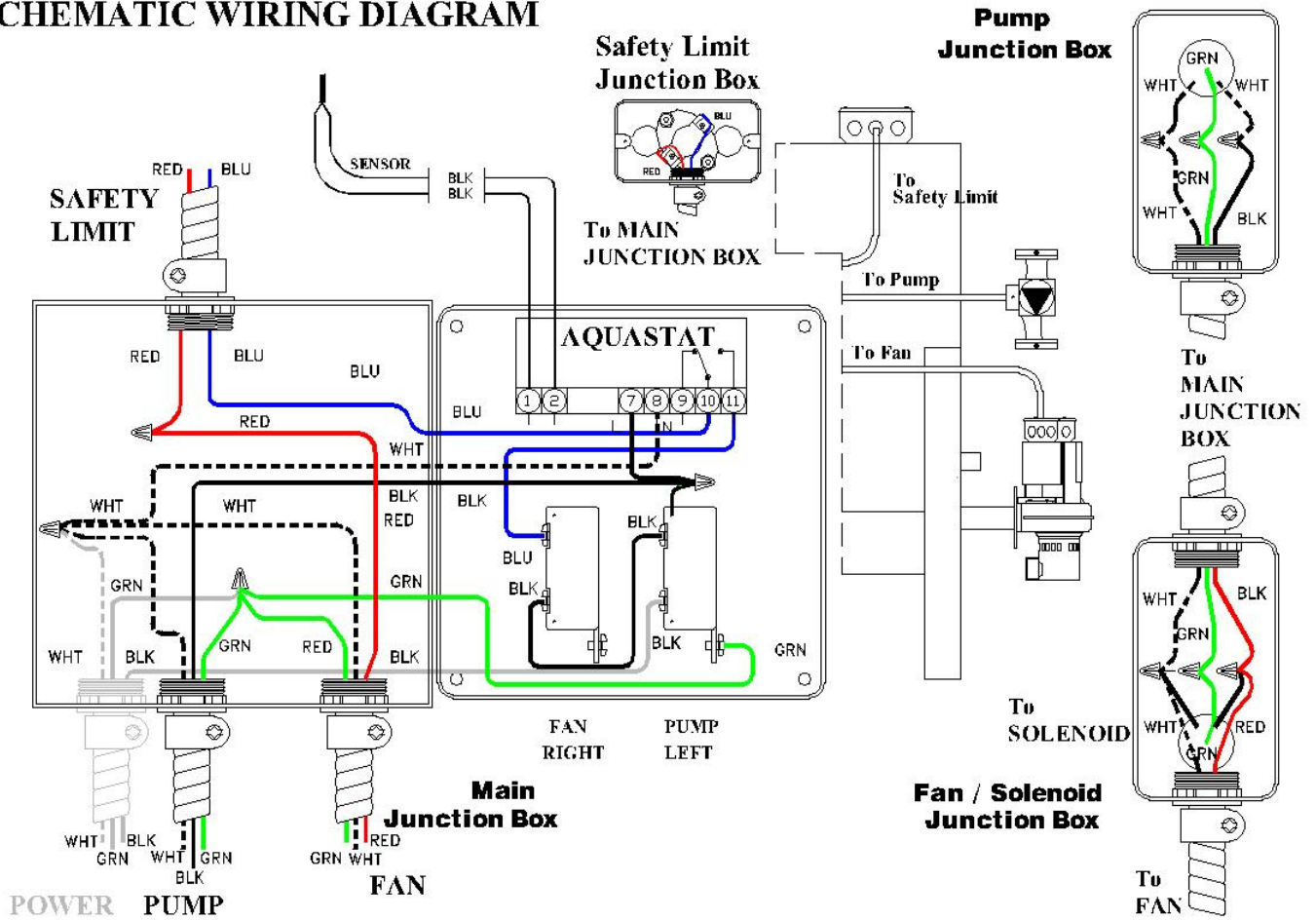

LADDER WIRING DIAGRAM

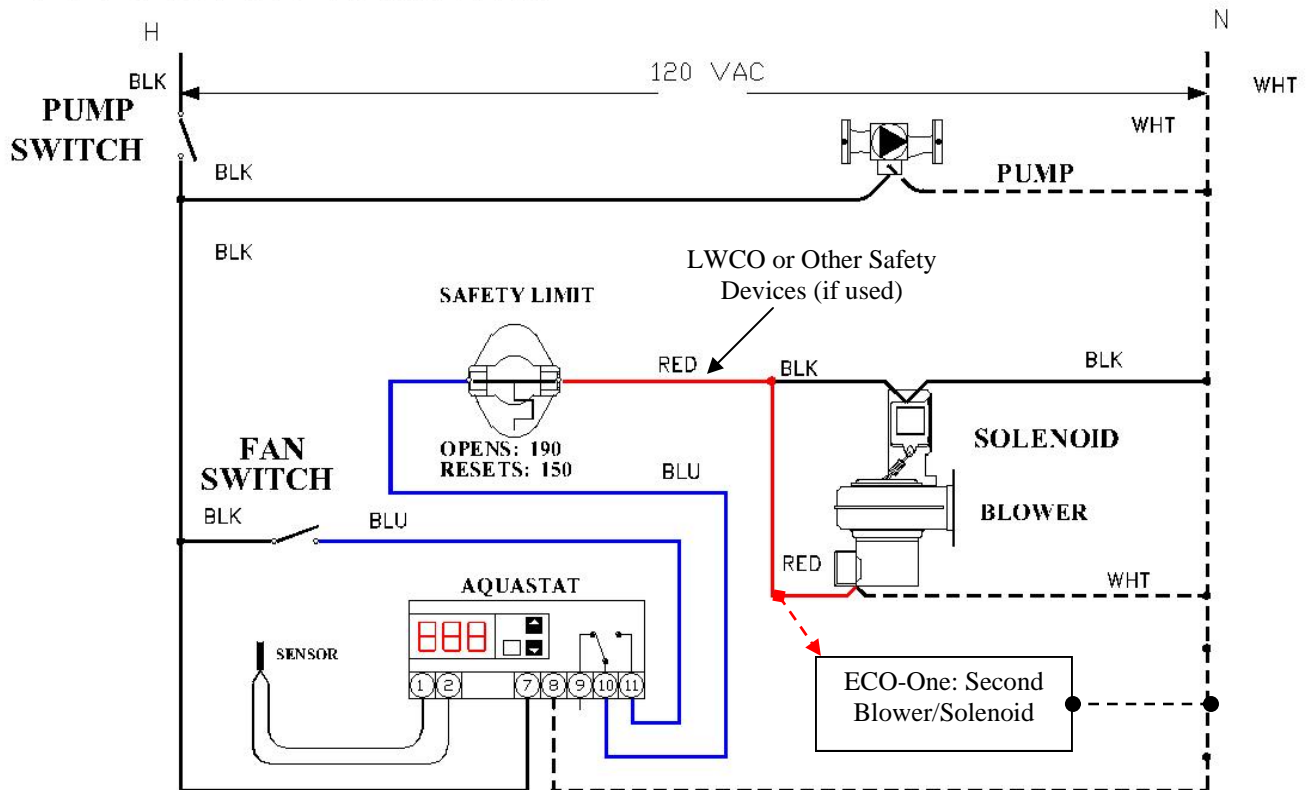

INSTALLATION: GENERIC SYSTEMS

WARNING

The system diagrams provided are only suggested schematics for generic systems and do not purport to show all required components necessary to meet all required codes. Complex systems should be designed by a professional heating system installer.

GENERAL COMMENTS

Piping at the Appliance

The Piping at the Appliance does not change with most applications. In the Applications Drawings on pages 29 to 34 it is not shown but is assumed to be as shown on this page.

Pumps

A Pump is required. This pump is typically located at the appliance but can alternately be located in the structure being heated. Additionally, depending on Transfer Line length and system design, additional pumps might be required. All pumps must be appropriately sized for the application to ensure optimum performance. If using isolation flanges, ensure that they are positioned so that shut off is accessible.

Pump motors are water lubricated and can burn out if incorrectly mounted. The motor canister must be horizontal. Body has arrow on the front that indicates direction of flow. To rotate body, remove the four body bolts, rotate body and replace bolts. Ensure the junction box is NOT located underneath the circulator. When boiler is operating, pump will feel hot to the touch. This is normal.

Expansion Tank

Hydronic heating systems require an Expansion Tank to allow water to expand/contract as it heats or cools without adversely affecting system pressure. A diaphragm type Expansion Tank is recommended. The tank can be installed in the heated structure or at the appliance. The tank must be installed vertically, typically it is attached to the bottom of an Air Scoop. Ensure that the Expansion Tank is large enough to handle both the volume of the appliance and the volume of the system.

Air Elimination

Install an Air Scoop (or similar Air Separator) and Air Vent either in the heated structure or at the appliance. Attach the Expansion Tank to the bottom of the Air Scoop and install the resulting assembly at a high point.

Open System Tank

If used, the Open System Tank is installed in place of the Fill Cap. When the Open System Tank is used, the Expansion Tank, Air Scoop and Air Vent are not necessary.

If the heating system is higher in elevation than the Open System Tank (or involves heat emitters on a second floor) or if the Aqua-Therm is being connected to an existing boiler and hot water heating system, then a Heat Exchanger is required. The Heat exchanger can be installed at the appliance or in the structure being heated. Typically it is in the structure being heated so that the transfer lines contain antifreeze, but the existing boiler system does not have antifreeze. Note that a pump is required on either side of the heat exchanger.

TYPICAL PIPING AT THE APPLIANCE

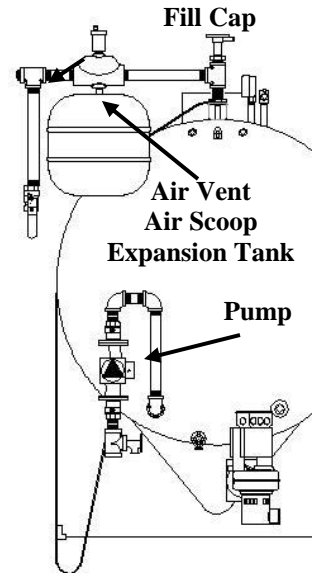

OPEN SYSTEM TANK PIPING

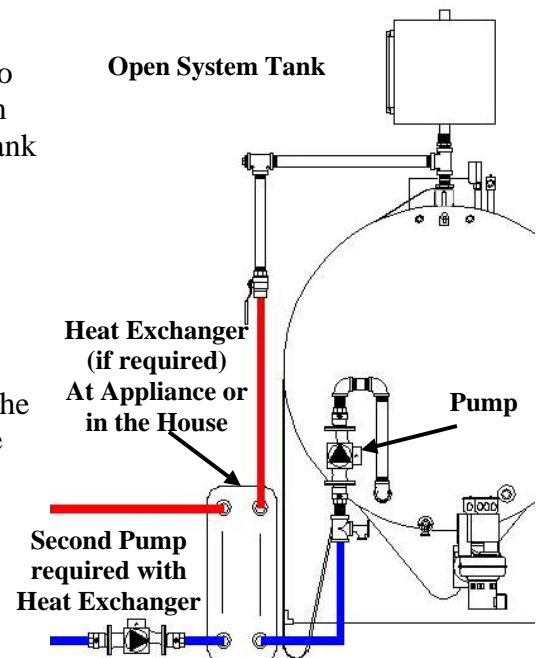

TYPICAL SYSTEM SCHEMATICS: CONNECTING TO AN EXISTING BOILER

CAUTION

Do not install the safety limit aquastat on PEX or PEX-AL-PEX tubing. Plastic does not transfer heat well as metal and the aquastat might not operate properly. It must be strapped onto a copper line.

Operation:

- Water circulates continuously through the **AQUA-THERM** and the transfer lines.
- If the thermostat calls for heat, the existing boiler will start it's pump, but the burner will not fire as long as water temperature is above the boiler aquastat setting.
- If the temperature from the **AQUA-THERM** falls below the boiler aquastat setting, the boiler will fire as normal.

Piping Installation:

- Install closely spaced Tee connections (4" to 6" apart) between the existing boiler pump (if on the return side of the existing boiler) and the cold return of the existing boiler as shown in the diagram.
- Connect the "hot" line from the **AQUA-THERM** to the Tee closest to the return of the existing boiler.
- Connect the "cold" line from the **AQUA-THERM** to the Tee farthest to the return of the existing boiler.
- Mount the safety limit aquastat to hot water line close to existing boiler
- Ensure that neither the existing boiler nor the **AQUA-THERM** are isolated from an expansion tank.

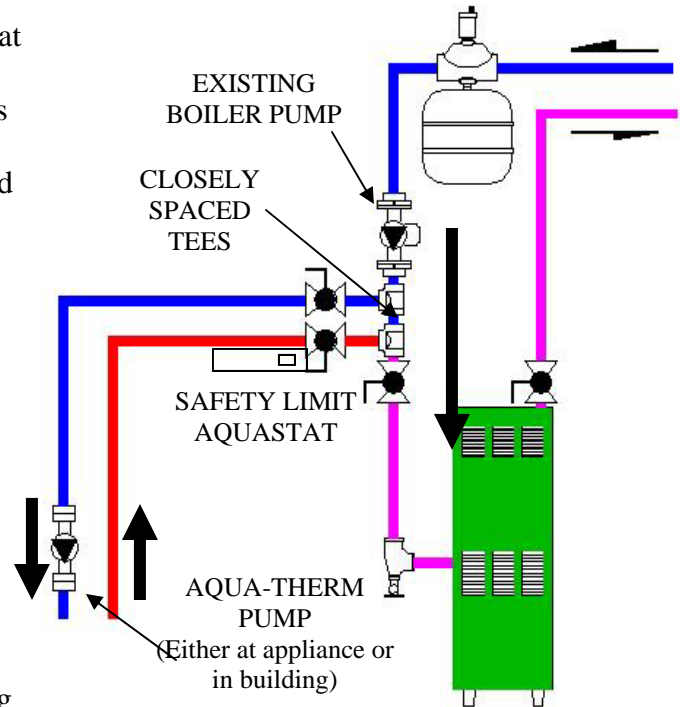

DANGER

Do Not remove or alter the Relief Valve on the existing boiler. Failure to do so could result in explosion causing severe injury, death or property damage.

DANGER

For your safety, **turn off electrical power supply at service entrance panel before making any electrical connections** to avoid possible electric shock hazard. Failure to do so can cause severe personal injury or death.

Safety Limit Aquastat (if used):

Turns on existing pump if boiler overheats. Set 10° higher than fan control Aquastat on boiler, but never over 200°F. It is wired with low voltage.

Wiring Installation:

- Route low voltage wire from 'R' screw and 'W' spade on safety limit Aquastat into the existing relay on boiler or to zone valve. If you have several zones in your heating system, wire safety Aquastat to allow circulation through largest zone.

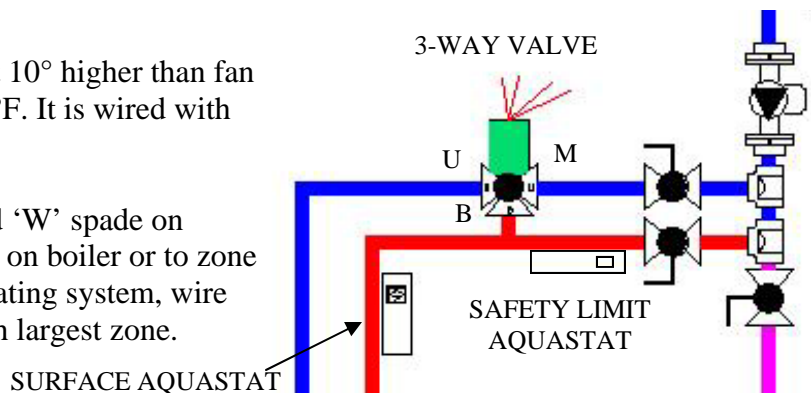

ALTERNATIVE PIPING w/ 3-WAY VALVE

Alternative Piping:

Pipe in a 3-way Zone Valve as shown, wired to an Aquastat strapped to the Hot line from the Appliance. If **AQUA-THERM** temperature falls below the Aquastat setpoint (indicating that the unit is out of wood), the 3-Way Valve will bypass water back to the unit, isolating it from the existing boiler system.

TYPICAL SYSTEM SCHEMATICS

HIGH TEMPERATURE FORCED AIR

CAUTION

Do not install the safety limit aquastat on PEX or PEX-AL-PEX tubing. Plastic does not transfer heat as well as metal and the aquastat might not operate properly. It must be strapped onto a copper line.

NOTICE

For simplicity, the **AQUA-THERM** and the near appliance piping are not shown. They are assumed to be as shown on page 28.

AQUA-THERM PUMP
(Either at appliance or in building)

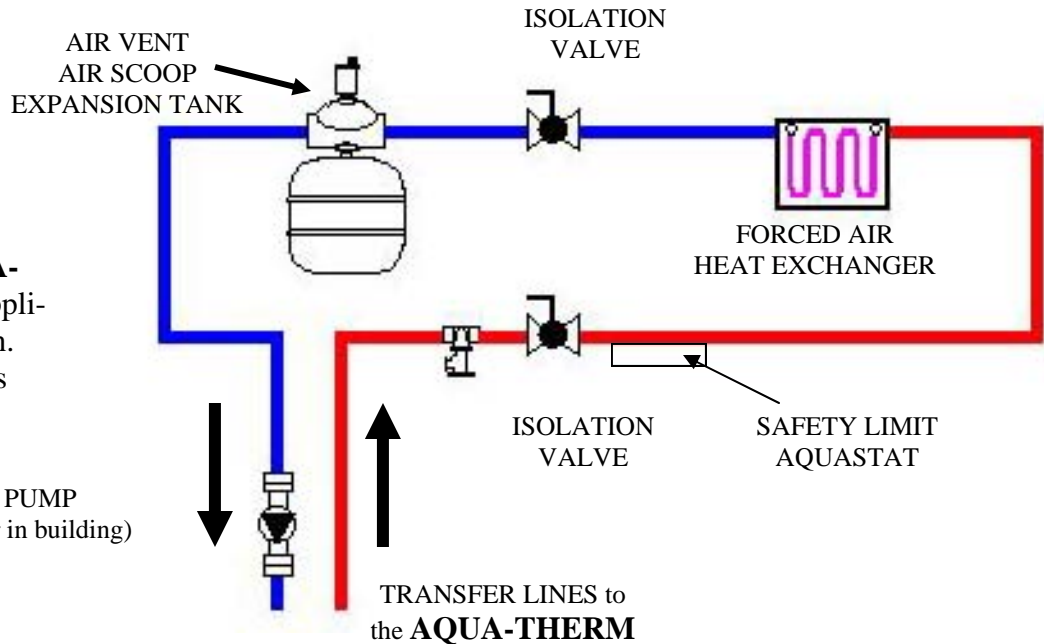

Operation:

- Water circulates continuously between the **AQUA-THERM** and the Forced Air Heat Exchanger.
- The Forced Air Heat Exchanger is located in the existing furnace plenum.
- “New” Thermostat in the house cycles the blower on the furnace. Existing Thermostat will cycle the furnace burner if the AQUA-THERM can not keep up with the load.

Piping Installation:

- Ensure that the Expansion Tank is not isolated from the **AQUA-THERM**.
- Install the Forced Air Heat Exchanger in the plenum as close as possible to the furnace fan. Ensure that no air is allowed to bypass the heat exchanger. The exchanger must fill the entire plenum cavity. All air from the furnace fan must be forced through the exchanger. Baffles may need to be installed below the exchanger to direct the airflow.
- Position Heat Exchanger so air won’t be trapped in the “U’s”. Drawing above is illustrative only — the tubes should be horizontal. The hot (supply) line from boiler should enter the bottom opening on the heat exchanger.
- If the furnace has an air conditioning ‘A’ coil, the forced air heat exchanger can be placed above or below the ‘A’ coil.

NOTICE

Dust can accumulate on the coil so it’s good to allow room for vacuuming between fan and coil.

TYPICAL SYSTEM SCHEMATICS

HIGH TEMPERATURE FORCED AIR

Electrical Installation:

DANGER

For your safety, **turn off electrical power supply at service entrance panel before making any electrical connections** to avoid possible electric shock hazard. Failure to do so can cause severe personal injury or death.

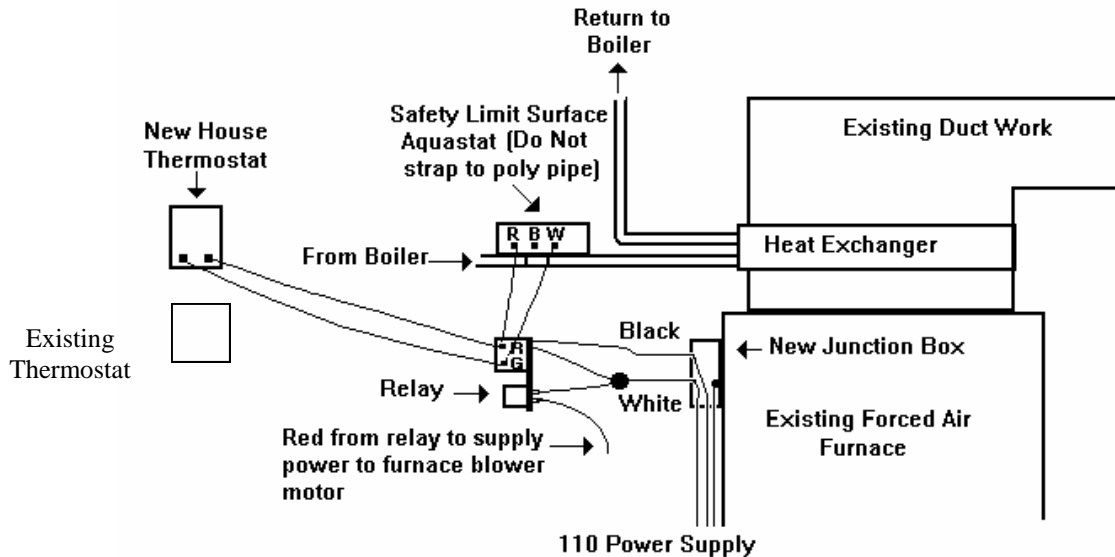

- The relay and safety limit surface (strap on) Aquastat will be installed in the building being heated. (Thermostat not included in kit.)
- Mount a 4" steel junction box (not included) on side of existing forced air furnace. The relay mounts on this box with the low voltage side exposed (side with 'R' & 'G' terminals where thermostat wires are connected). Junction box need not be large enough to house entire relay.

CAUTION

Do not install the safety limit Aquastat on PEX or PEX-AL-PEX tubing. Plastic does not transfer heat as well as metal and the Aquastat might not operate properly. It must be strapped onto a copper line.

- From the same line that is feeding existing furnace, route 110-volt power supply to junction box.
- Connect the black wire from power supply to the two black wires from back side of relay.
- Connect the white wire from power supply to white wire on relay.
- The red wire from relay powers furnace fan, splice directly to wire supplying power to fan. **DO NOT** connect to furnace control board, damage to the furnace control may result. The brown wire on relay is not used, cap with a wire nut.
- An additional thermostat should be installed in your living quarters. From the thermostat contacts run low voltage wires to the 'R' and 'G' screws of relay.
- Mount the safety limit Aquastat to hot water line, close to the heat exchanger.
- Route a low voltage wire from 'R' screw on safety limit Aquastat to 'R' screw on relay.
- Route a wire from 'W' spade on safety limit Aquastat to 'G' screw on relay.

If the existing forced air furnace is electric or has a 240-volt blower motor, a 220-volt relay may be required, rather than the 110-relay included in the standard package.

TYPICAL SYSTEM SCHEMATICS

HIGH TEMPERATURE BASEBOARD

CAUTION

Do not install the safety limit aquastat on PEX or PEX-AL-PEX tubing. Plastic does not transfer heat well as metal and the aquastat might not operate properly. It must be strapped onto a copper line

USING 3-WAY ZONE VALVE

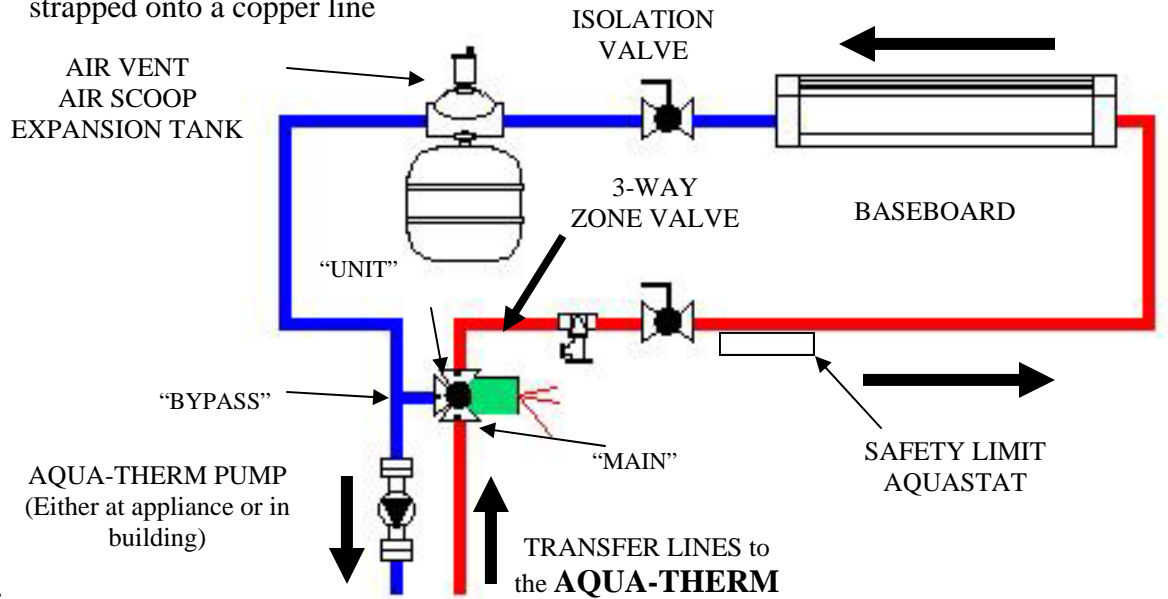

NOTICE

For simplicity, the **AQUA-THERM** and the near appliance piping are not shown. They are assumed to be as shown on page 28.

USING PRIMARY SECONDARY PIPING

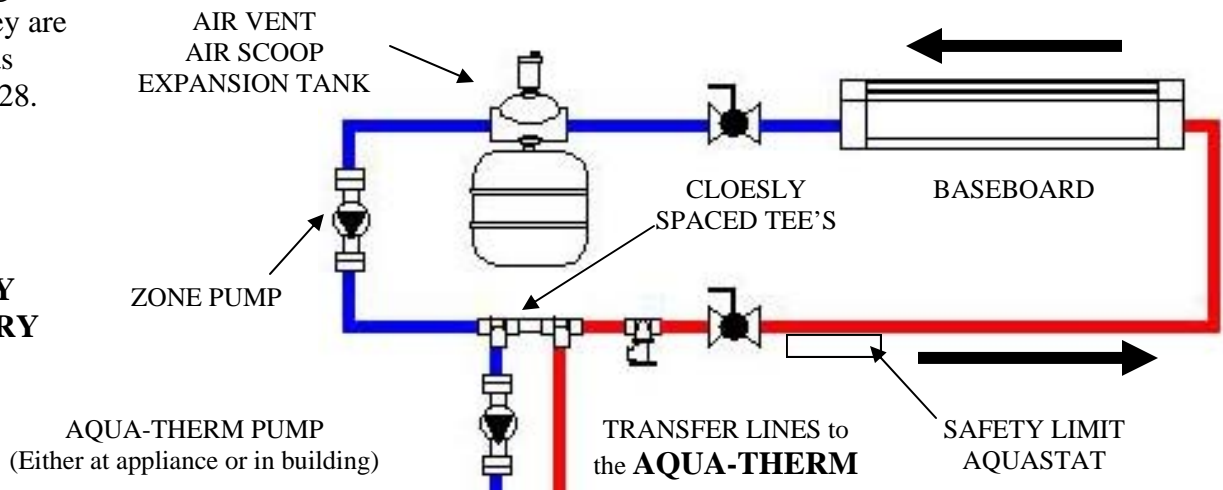

Operation:

- Water circulates continuously between the **AQUA-THERM** and the structure being heated.
- If using 3-Way Zone Valve, when the thermostat calls, the valve repositions “Main to Unit” to allow water to flow to the Baseboard.
- If using Primary Secondary Piping, when the thermostat calls, Zone Pump turns on, allowing water to flow to the Baseboard.

Piping Installation:

- Ensure that the Expansion Tank is not isolated from the Appliance.
- If using 3-Way Valve, pipe as shown above.
- If using Primary Secondary Piping:
 - Position closely spaced Tees 4 to 6 inches apart.
 - For the Zone Pump use either a Zoning Circulator (with built-in relay) or a regular pump with a Zone Pump Control Panel.

TYPICAL SYSTEM SCHEMATICS

HIGH TEMP BASEBOARD SYSTEM

Electrical Installation:

DANGER

For your safety, **turn off electrical power supply at service entrance panel before making any electrical connections** to avoid possible electric shock hazard. Failure to do so can cause severe personal injury or death.

WIRING SHOWN ONLY
FOR 3-WAY VALVE
OPTION.

FOLLOW DIRECTIONS
BELOW FOR PRIMARY
SECONDARY WIRING
OPTION

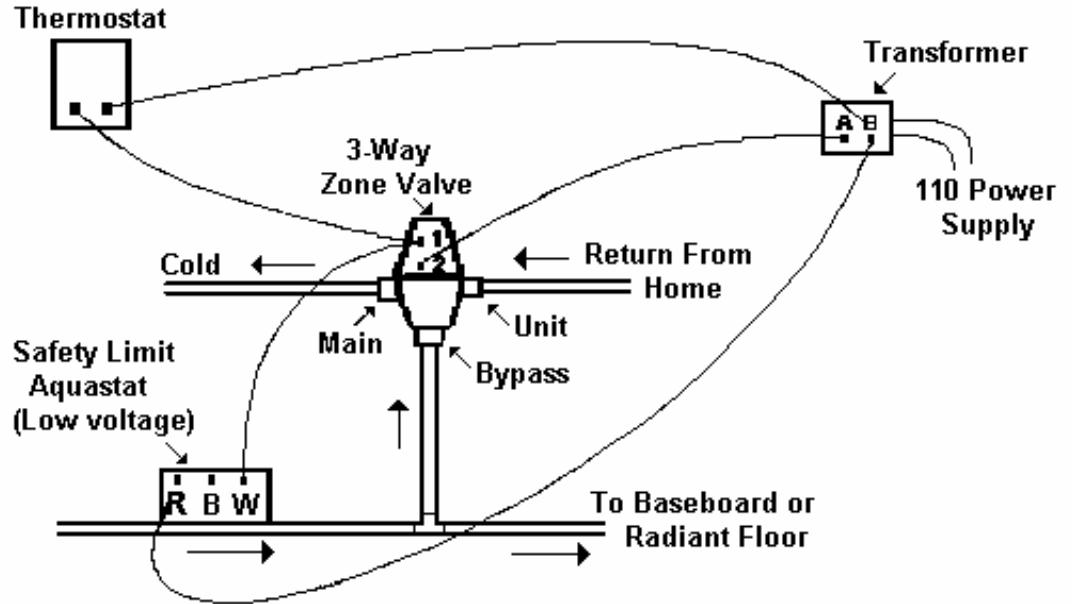

- The relay and safety limit surface (strap on) Aquastat will be installed in the building being heated. (Thermostat not included in kit.)

CAUTION

Do not install the safety limit Aquastat on PEX or PEX-AL-PEX tubing. Plastic does not transfer heat well as metal and the Aquastat might not operate properly. It must be strapped onto a copper line.

Wiring 3-Way Valve:

- Route 110-volt power supply to transformer.
- Route wire from 'A' on transformer to '2' on zone valve.
- Route wires from 'B' on transformer to 'R' on safety limit Aquastat and to thermostat.
- Route wire from thermostat to '1' on zone valve.
- From 'W' on safety limit Aquastat, run wire to '1' on zone valve.

Wiring Primary Secondary with a Zoning Circulator:

- Route wire from thermostat to 'R' on safety limit Aquastat.
- Route wire from 'W' on safety limit Aquastat to '1' on Zoning Circulator.
- Route wire from '2' on Zoning Circulator to thermostat.

Safety Limit Aquastat – opens zone valve if boiler overheats. Set 10° higher than fan control Aquastat on boiler, but never over 200°F.

TYPICAL SYSTEM

SCHEMATICS:

LOW TEMP RADIANT or MIXED TEMP SYSTEM

Low temperature radiant systems require some sort of tempering device, most commonly a thermostatic mixing valve. Low temperature and High temperature applications can be easily accommodated by the **AQUA-THERM**.

Mixing Valve Details:

- The mixing valve **MUST** be piped such that a pump “pulls” water through it.
 - The best location for the pump is 10” to 12” down stream of the “Mixed” port of the mixing valve.
- Multiple pumps in parallel require check valves on the outlet of each pump.

AQUA-THERM PUMP
(Either at appliance or in building)

Low Temperature Radiant:

- Recommend Primary Secondary piping be used.

Mixed Temperature Systems:

- Follow the instructions for high temperature systems as modified by the diagrams below.
- Refer to the Applications Manual for specific applications.
- Call Aqua-Therm Technical services with specific design questions.

Low Temperature Radiant With High Temperature Forced Air

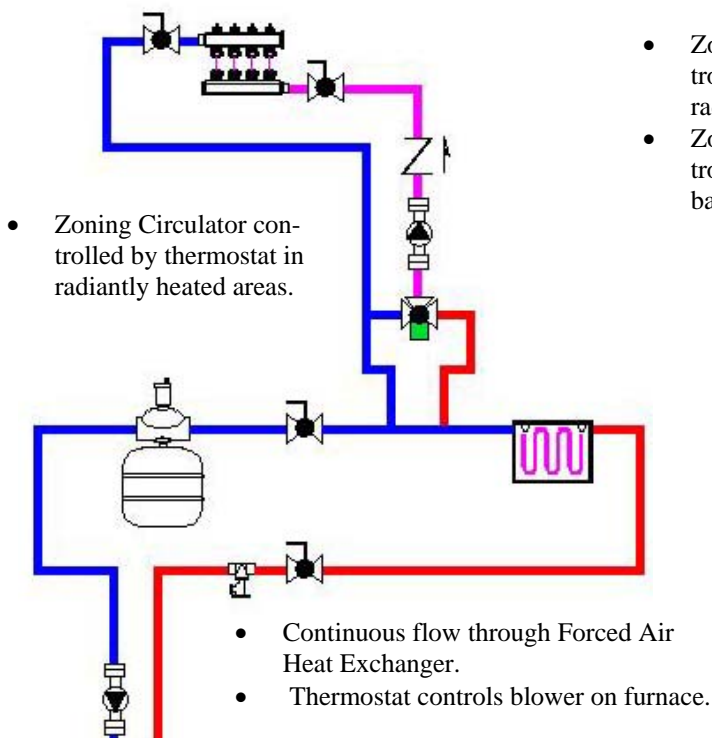

Low Temperature Radiant With High Temperature Baseboard

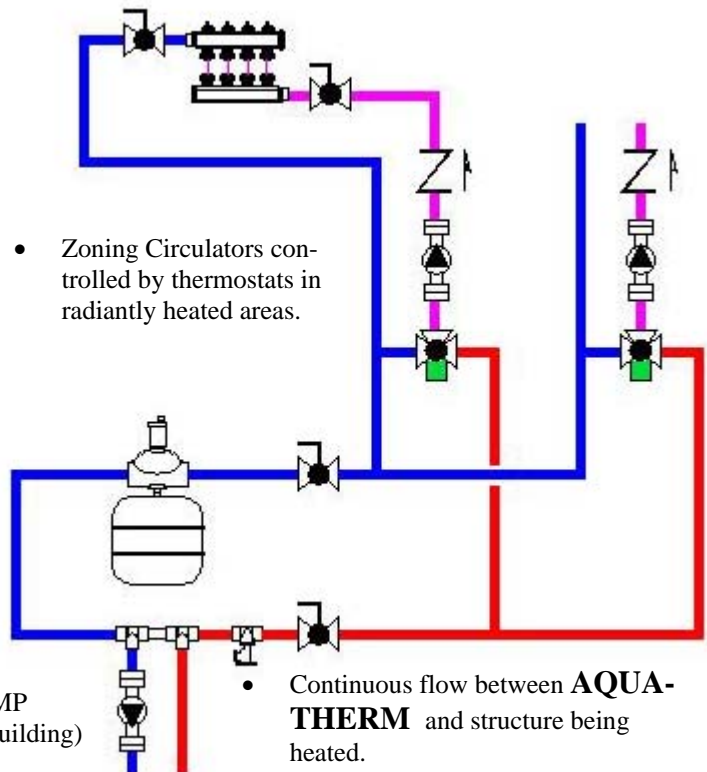
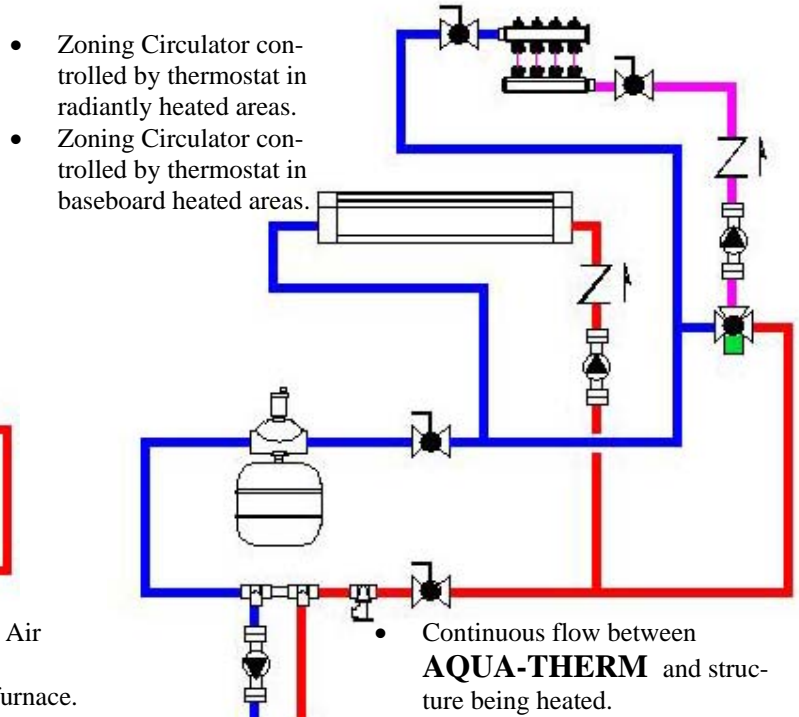

ACCESSORIES: SIDEARM HEAT EXCHANGER

Kit Includes:

Water-to-Water Heat Exchanger
3/4" Mix Valve

Operation:

The domestic water runs through the smooth inner tube. Heat is transferred from the boiler water that is running through the outer jacket. As the domestic water starts to heat up it rises, causing it to thermosiphon counter clockwise through the water heater. Between the outer and inner tubes, there is a small air chamber which protects your domestic water supply from being contaminated. If a leak should develop, the water would drain out the exchanger. This assures that even with an anti-freeze solution in the **AQUA-THERM**, the domestic water is safe.

The domestic water heat exchanger should be installed vertically next to the existing water heater.

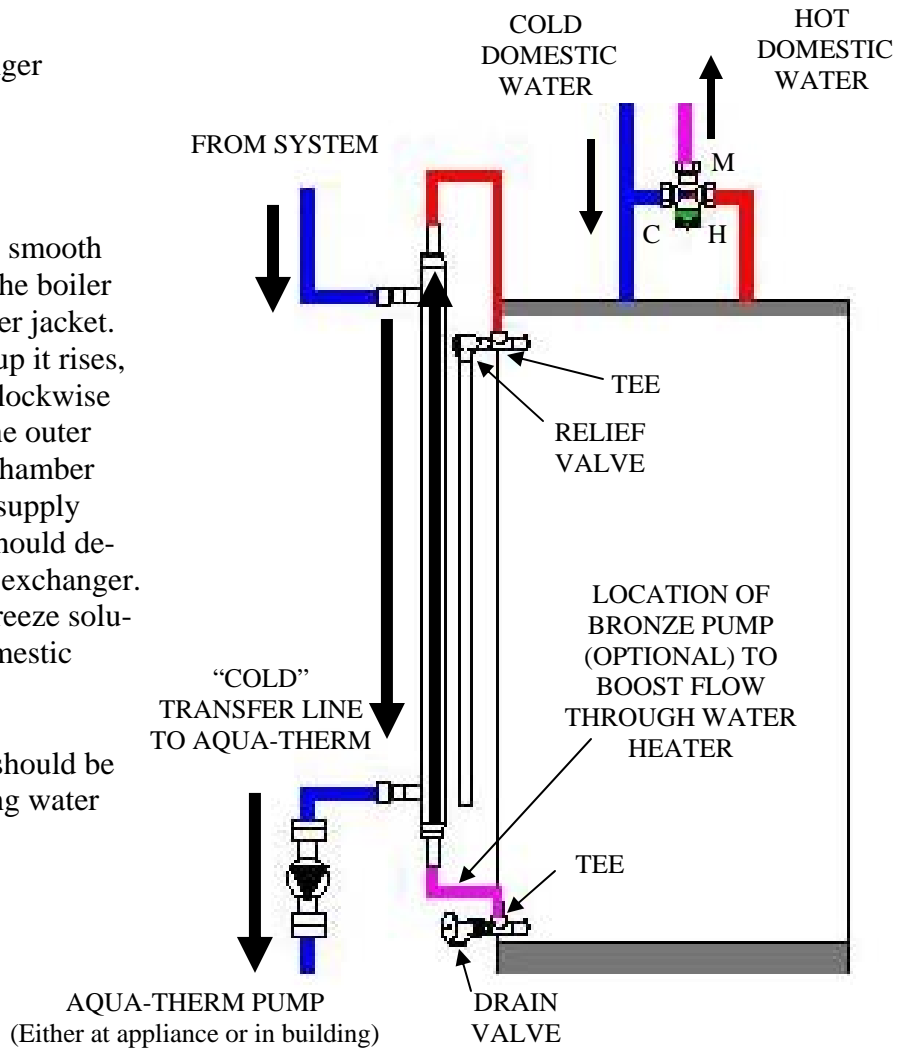

Piping Installation:

- Pipe into the return line to the **AQUA-THERM** (just prior to the “cold” transfer line).
- Plumb the **AQUA-THERM** water such that it flows in the top side port and out the bottom side port.
- Connect the top and bottom copper tube into the existing water heater as shown.

DANGER

Hot water mix valves cannot be used for tempering water temperature at fixtures. Severe bodily injury (i.e., scalding or chilling) and/or death may result depending upon system water pressure changes and/or supply water temperature changes. Anti-scald devices should be used at fixtures to prevent possibly injury.

NOTE

Sidearm Heat Exchanger is designed to SUPPLEMENT NOT REPLACE the existing Water Heater. DO NOT disconnect the heat source (gas, oil, electric) from the existing Water Heater. The AQUA-THERM is designed to be the primary heat source for a structure. It is not intended to be fired for summer hot water use.

ACCESSORIES: EXHAUST DRAFT HOOD

Kit Includes:

- 1) Draft Hood
- 2) Blower Inlet Transition
- 3) Blower
- 4) Blower Outlet Transition
- 5) Adjustable Exhaust Pipe
- 6) Exhaust Termination

Operation:

Exhaust Hood mounts above the AQUA-THERM Loading Door. Blower is wired into a separate switch so that it can be energized when loading the appliance to exhaust smoke out of the building.

Installation:

- Hang the Draft Hood from the forward lifting lug.
- Connect components as shown. Note that only the labeled components are included in the kit. Additional components will be required. Use 6" galvanized as necessary.
- Termination should be outside of the building, with the screen side pointing down.
- Wire the Blower into a common light switch (not provided).

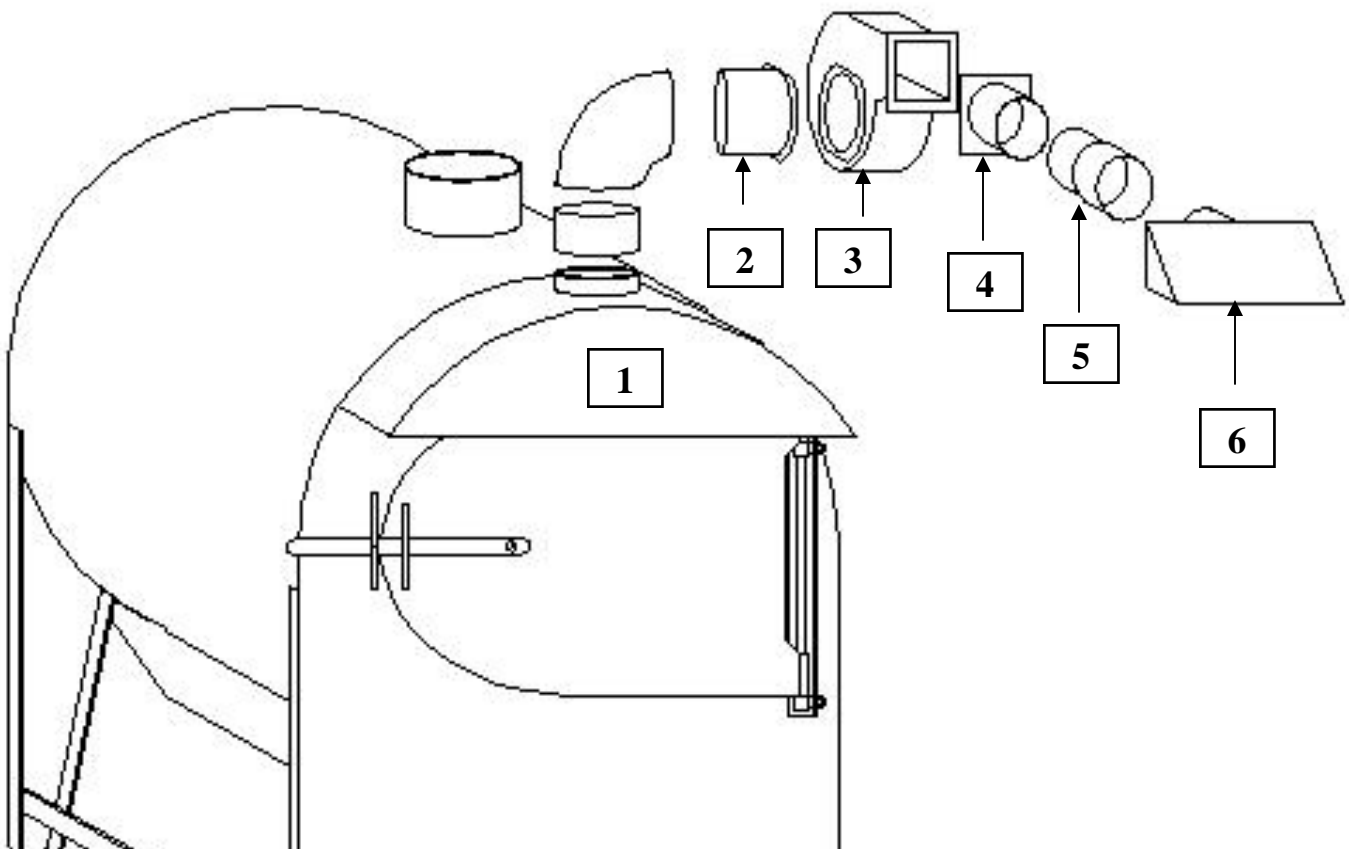

START-UP: INITIAL FILL

INITIAL FILL OVERVIEW:

- 1.) Fill and isolate **AQUA-THERM**. Pressure test.
- 2.) Test water to determine if water treatment is necessary.
- 3.) Re-fill system with water and bleed air.
- 4.) Inspect system for leaks. Drain and repair as necessary.
- 5.) Add Anti-freeze as necessary.

1. FILL, ISOLATE AND PRESSURE TEST

Though the **AQUA-THERM** is factory pressure tested, it should be tested in the field to ensure that no damage has occurred during shipping. Isolate the **AQUA-THERM** from the system prior to pressure testing.

- A.) Remove Fill Cap "X" (including the Fill Cap Neck) or Open System Tank
- B.) Plug the "X" Bung with a 3/4" NPT Plug.
- C.) Shut Appliance Isolation Valves "A1" and "B".
- D.) Shut small cap on top of Auto Air Vent.
- E.) Attach Hose to Drain Valve "C".
- G.) Connect the other end of the hose to a water source with pressure between 30 and 40 psi.
- H.) Slowly open Drain Valve "C" until test pressure on pressure gauge reaches no more than 29 psi. The Pressure Relief Valve "G" will discharge if pressure exceeds 30 psi.

The person pressurizing the Appliance must either be able to see the pressure gauge or must be in direct communications with someone who can see the pressure gauge.

DO NOT EXCEED 45 PSI.

Failure can result in severe personal injury, death or substantial property damage.

WARNING

DANGER

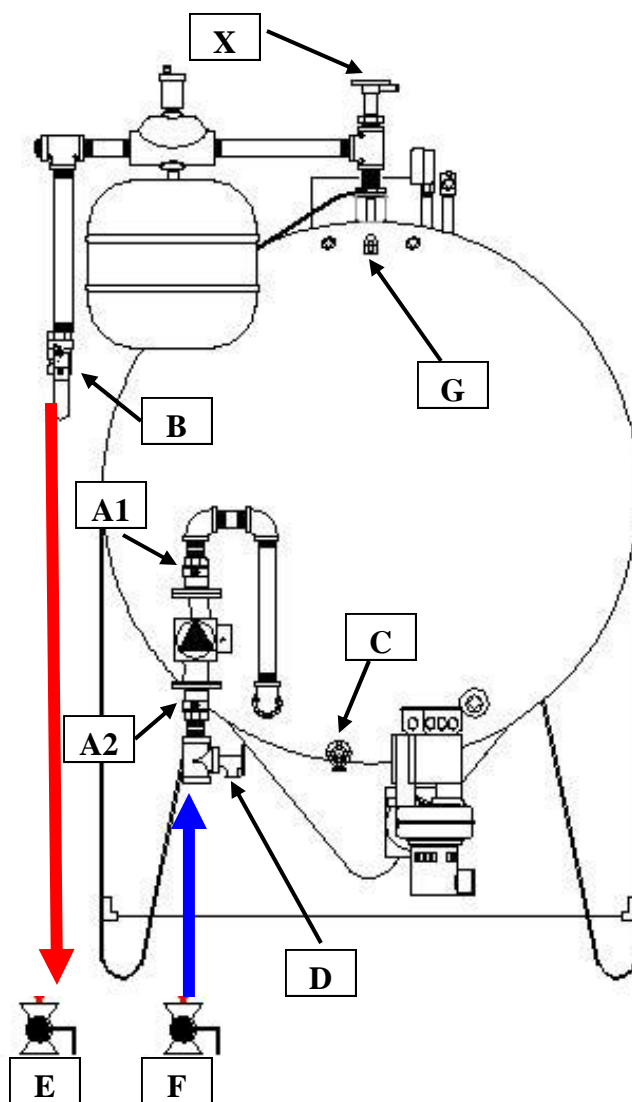

- I.) Test for no longer than 10 minutes at 29 psi. Ensure constant gauge pressure has been maintained throughout test. Check for leaks. Repair if necessary.

WARNING

Leaks must be repaired at once. Failure to do so can damage boiler, resulting in substantial property damage.

DANGER

Do not leave Appliance unattended. A cold water fill could expand as it heats up and cause excessive pressure, resulting in severe personal injury, death or substantial property damage.

- J.) Remove Hose from water source and slowly open Drain Valve "C" to depressurize the appliance.
- K.) Remove Plug from the Bung and re-install the Fill Cap Neck or Open System Tank.

DANGER

The Relief Valve must be Installed in the system prior to operation. Failure can result in severe personal injury, death or substantial property damage.

START-UP: INITIAL FILL (Cont.)

2. TEST WATER QUALITY

Test system water pH to determine if water treatment is necessary. Heating System water pH of 7.0 to 8.5 is recommended. Swimming pool pH test kits are readily available from other sources. Consult local water treatment companies for unusually hard water areas (above 7 grains hardness) or low pH water conditions (below 7.0). Use only water treatment designed for Hydronic systems. A corrosion inhibitor is required to be maintained per the Warranty (see page 51).

3. RE-FILL SYSTEM WITH WATER AND BLEED AIR

It is recommended to fill the system initially with water (even if Anti-freeze will be used) unless the temperatures are below freezing. This will make it easier to drain and refill if it is necessary to repair leaks or bleed out air.

It is important to bleed air correctly when filling the Appliance. Do not have Appliance pump running during filling and bleeding.

- A.) Shut Pump Isolation Flange “A1”. Ensure Isolation Valve “B”, Transfer Line Isolation Valves “E” and “F” in the house are all open.
- B.) Open both Drain Valves “C” and “D”.
- C.) Open pressure relief valve “G” and open Fill Cap “X”.
- D.) Attach garden hose to drain valve “C” and turn water on. The appliance will fill first because the ‘A1’ Pump Isolation Flange is closed. When water comes out the relief valve “G”, close it. When water comes out of Fill Cap “X”, re-install it. Monitor system pressure. Shut drain valve “C” if pressure exceeds 10 psi. If using the Open System Tank, fill until the Sight Glass has about 1—2 inches of water showing.
- E.) Water will flow through “B” filling the Transfer Line. Water will flow past “E” and “F” filling the other Transfer Line. When water is flowing freely from “D”, Shut “D”.
- F.) Open (do not remove) small cap on auto air vent. 10-20 gallons may be drained out before all air is out.
- G.) When the Transfer Lines are full and the system in the structure being heated are full, open “A1” and continue to fill until the pressure gauge reads approximately 10 psi or until 1-2” of water is visible in the Open System Tank sight glass.

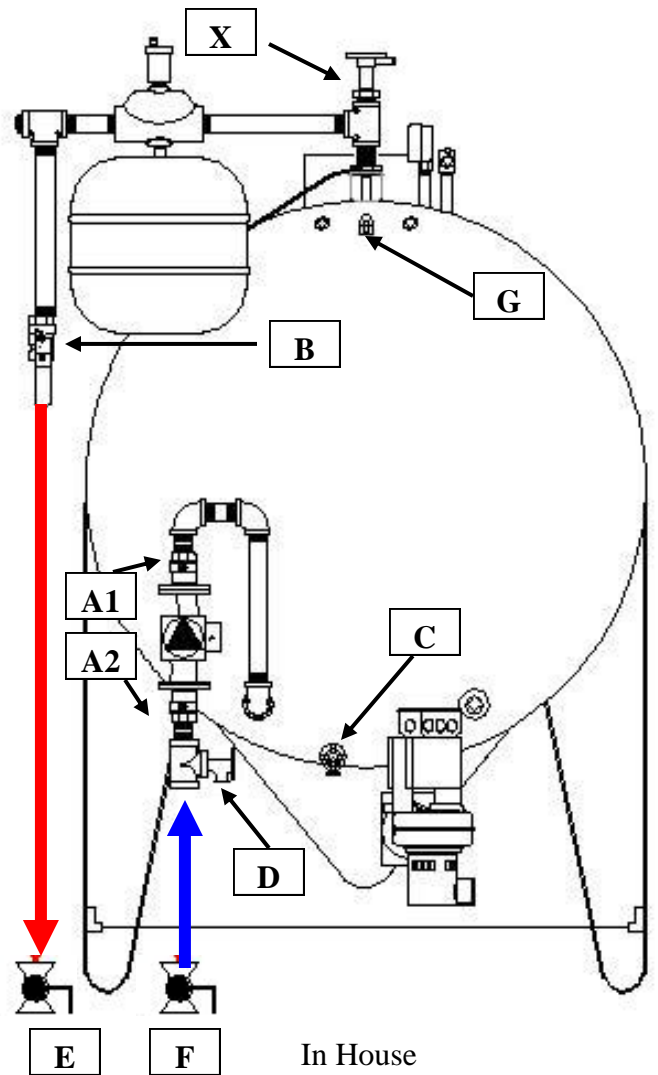

START-UP: INITIAL FILL (Cont.)

H.) Turn pump on. Verify that it is running by placing the blade of a screw driver against the pump motor, and the butt against your ear.

The pump will circulate water and any air should escape out the auto air vent or the Open System Tank vent. Pressure may drop from air escaping. Add more water with the garden hose. When adding more water, fill garden hose with water before attaching to the appliance to prevent from pushing more air into system.

5. INSPECT SYSTEM FOR LEAKS

After filling the appliance and system with water, **inspect all piping** throughout the system for leaks. If found, repair immediately. Repeat this inspection after the boiler has been started and the system has heated up.

WARNING

Leaks must be repaired at once. Failure to do so can damage the appliance, resulting in substantial property damage.

WARNING

Do not use **petroleum-based cleaning or sealing compounds** in the heating system. Severe damage to the appliance can occur, resulting in substantial property damage.

6. ADD ANTI-FREEZE

WARNING

Anti-freeze must be used in any systems where there is danger of freezing (ambient temperatures below 32 degrees F). Severe property damage can result.

Use only anti-freeze made especially for hydronic systems. Inhibited propylene glycol is recommended.

WARNING

Do not use **ethylene glycol, Automotive, RV or undiluted anti-freeze**. Use only Hydronic or Boiler Anti-freeze. Follow all of Anti-freeze Manufacturer's Instructions. Severe personal injury, death or property damage can result.

WARNING

Failure to add anti-freeze or corrosion inhibitor will void the warranty.

- A.) Determine anti-freeze quantity according to system water content. AQUA-THERM water content is listed on page 5. Remember to include system water content.
- B.) A 50% solution of propylene glycol/water provides maximum protection to about -30 °F.
- C.) Follow anti-freeze manufacturer's instructions.
- D.) **Anti-freeze Tester instructions are provided on page 44.**
- E.) Local codes may require back flow preventer or actual disconnect from city water supply.
- F.) To add anti-freeze, drain the water from system by opening drain valve "D".
- G.) Close drain valve "D" when the proper amount of water has been drained out of the appliance.
- H.) Attach discharge hose from a transfer pump to drain valve "C". Shut valve "A1". Pump the desired amount of anti-freeze through value "C" into the appliance.
- I.) Raise system pressure to 5 to 10 psi. (cold) or to 1-2" inches of water visible in the Open System Tank sight glass.

WARNING

Do not use an automatic fill valve in a system with anti-freeze. Glycol will leak before the water begins to leak, causing glycol level to drop. Added water will dilute the anti-freeze, reducing the freeze protection level. Severe property damage can result.

OPERATION

FOLLOW ALL SAFETY PRECAUTIONS

START-UP: CHECKLIST

- Fill and Flush System
- Pressure Test Boiler
- Inspect System Piping
- Verify Water Chemistry/pH
- Verify Anti-freeze Concentration
- Open all Isolation Valves
- Verify Pump Running
- Verify Relief Valve Installed and Operational
- Verify Chimney is Installed and Clear
- Inspect door gasket
- Inspect door tightness
- Verify Aquastat operation
- Verify proper blower operation
- Review all safety precautions



BEFORE STARTING A FIRE

- Verify "START-UP CHECKLIST" is complete.
- **ENSURE** the isolation valves are open.
- Start the Pump . The pump is lubricated with water. **DO NOT** run dry.
- Cycle the fan to check for proper draft fan operation.
- Ensure the Shutter on the Draft Fan in the back of the appliance closes properly when the fan is stopped.
- Inspect the Loading Door gasket before lighting the first fire and a few days after, looking for any indications of a poor seal.

FUEL SELECTION

Burn only split cordwood that has been seasoned for 12-18 months. Burning unseasoned wood is wasteful and inefficient using much of the combustion energy to boil off the excess moisture. Ideally the wood should be split to aid in seasoning and should be around 25% moisture content by weight.

The following are general guidelines for wood selection:

- Hardwoods burn better than softwoods.
- Larger pieces burn better than small pieces.
- 25% moisture content is optimum:
 - Higher moisture content wastes energy boiling off water.
 - Lower moisture content burns rapidly and inefficiently.

OPERATION (Cont.)

DANGER

DO NOT use gasoline, kerosene or other flammable liquids. To do so could cause a flash fire or explosion resulting in serious personal injury and property damage.

WARNING

DO NOT BURN GARBAGE, HOUSEHOLD WASTE OR YARD WASTE. In most areas this is illegal. The unit is designed to burn seasoned cord wood, burning other materials can reduce the life of the unit and will void your warranty.

FUEL STORAGE

- Locate the appliance to provide access to wood supply.
- Wood should be split, stacked and seasoned for one year prior to use.
- Wood should not be stored within the minimum clearance to combustibles stated on page 10.
- Ensure that wood storage does not impede maintenance access to the sides or back of the appliance.
- While placing the appliance in a site built structure allows space for storing some wood, the wood still must not be stored within the minimum clearances to combustibles or such that it restricts access for maintenance of the appliance.

LIGHTING THE INITIAL FIRE

- A.) Build a **SMALL** fire. Allow the water temperature to rise. When the water temperature reaches 120°F, set the draft control Aquastat to 110°F. The draft fan should stop and the shutter close. Reset to operating temperature of 160 - 180°F.
- B.) If a safety limit Aquastat is used, set the safety limit Aquastat below water temperature. In a hot water baseboard system the zone valves should open and the circulating pump should start. In a forced air system the furnace fan should start. Reset to 10° higher than fan control Aquastat setting. Never set safety limit Aquastat higher than 200°F.
- C.) Monitor water pressure or water level if using the Open System Tank. Maintain about 18 psi (hot water pressure) by adding water as air is purged from the system. It may take several days operation to purge all the air. **ENSURE** the vent opening on the automatic air vent is clear and the cap is loose to allow air to escape. This vent always stays open with the cap halfway unthreaded.

NOTE

Fill stove to about 10 psi (cold) pressure will rise as system temperature rises maintain 18 psi (hot). If using Open System Tank maintain about 1-2" in sight glass (cold) and 6-7 " (hot).

Condensation in the firebox will occur for the first 3 or 4 days of operation resulting in water or water/creosote combination running out of the ash door. This should clear up in less than a week. You may want to place a pan under ash door to keep concrete clean.

Firing the AQUA-THERM

- **NEVER** start a fire without water in the system. Damage to the appliance and controls will result.
- Load the appliance with regard to the required heat load. On mild days, load less fuel in to the appliance. A small, intense fire will burn cleaner, more efficiently and with less creosote formation than a large smoldering fire.
- Do not load the appliance above the top of the loading door.
- Start the fire with crumpled paper and kindling beneath the logs.
- Close the door securely.
- Turn the draft fan on.

OPERATION (Cont.)

- The **AQUA-THERM** will maintain water temperature based on the Aquastat settings.
- Heated structure temperature is controlled by a thermostat in the structure.
- The Loading Door and Ash Removal Door must tightly shut and the seals maintained in good condition during operation, otherwise overheating will occur.

When loading:

- Place FAN switch in OFF position.
- Open Loading door – pausing momentarily between the first latch and the safety latch to allow any combustion gases to burn off.

WARNING

The **AQUA-THERM** will not operate without electrical power. The combustion air shutter **MUST NOT** be manually opened or altered for any reason; overheating will result.

WARNING

Loading Door and Ash Door must be closed and latched during operation. Failure to latch door will result in overheating which could damage the appliance and controls.

In the event of overheating

- A.) The High Temperature Safety will shutdown the Blowers until temperature at the Safety falls below 150°F. The Pump will continue to run. The Temperature Relief Valve will open at 210°F, ensure that it discharges to a suitably sized container (usually 5 to 10 gallons).
- B.) Manually turn off the draft fan at the fan switch (place switch in “OFF” position).
- C.) **Do not turn off pump.**
- D.) Turn the thermostats fully up in the structure being heated by Aqua-Therm to remove heat from the unit as fast as possible.
- E.) Allow the appliance to cool down.
- F.) If the Aqua-Therm does not cool down then, with a shovel, remove as much of the wood and coals from the firebox. Place the removed wood and coals away from combustibles.
- G.) Once the unit has cooled down and the Temperature Relief has shut:
 - Determine and correct the cause of the overheating
 - Refill the system if necessary

Creosote Formation

All wood burning devices create some creosote. Creosote vapors condense and accumulate in the relatively cool chimney flue. When ignited this creosote makes an extremely hot fire. It is better to build a small, intense fire than a large smoldering one that will create more creosote. The chimney connector and chimney should be inspected at least monthly during the heating season to determine if a creosote buildup has occurred. If creosote has accumulated it should be removed to reduce the risk of a chimney fire.

In the event of a chimney fire:

- A.) Manually turn off the draft fan at the fan switch (place switch in “OFF” position).
- B.) Leave the doors securely closed.
- C.) **Do not turn off pump.**

Disposal of Ashes

Ashes should be placed in a metal container with a tight-fitting lid. The closed container of ashes should be placed on a noncombustible surface, well away from all combustible materials, pending final disposal. If the ashes are disposed of by burial in soil or otherwise locally dispersed, they should be retained in the closed container until all cinders have thoroughly cooled.

MAINTENANCE

Keeping the **AQUA-THERM** in good repair will result in more efficient operation and longer appliance life. You are responsible for safely maintaining the unit. Follow the **Service and Maintenance** procedures given throughout this manual and in component literature shipped with the appliance.

DANGER

Failure to perform the service and maintenance could result in damage to the boiler or system. Failure to follow the directions in this manual and component literature could result in severe personal injury, death or substantial property damage.

DAILY:

- **Grates** – For best performance level the coal distribution on the grates prior to each loading. (A garden hoe works well). There should be very little ashes on top of the grates. Ash build up will restrict air going through the grate, promoting incomplete combustion and creosote formation.
- **Auger out ashes** - Ashes should be augered out daily. Excessive buildup of ashes in the ash trough will eventually plug up the unit. (An oil change pan works well to catch ashes).

MONTHLY:

- Check above upper baffle for soot and creosote. Clean when soot layer is greater than 1/8 inch. Blow out with compressed air. Wear eye protection and a dust mask when blowing out the unit.
- Examine door gasket and draft fan shutter. Ensure airtight seal. Replace as required.

EVERY THREE MONTHS:

- Clean heat exchanger and baseboard radiators. Dust and dirt buildup reduces heat transfer.
- **Blower motor:** Place a few drops of S.A.E. 20 motor oil in each of the two oil cups.

WARNING

Use only **S.A.E. 20 motor oil** to lubricate the motor. Do not use universal household oils. Motor could be damaged, resulting in possible severe property damage.

END OF SEASON:

- **Power:** Turn off power supply at the appropriate circuit breaker.
- **Chimney:** Clean and inspect chimney. *Cap the chimney to keep rain water out.*
- **Firebox & Ash trough:** Remove ashes, soot, and hardened deposits from the fire chamber by using putty knife or wire brush. Coat inside of firebox with a light coat of motor oil to protect steel during the off season.
- **Doors:** Oil door hinges and latch guide.
- **Plumbing:** Shut all Isolation Valves. Ensure transfer line connections are tight.

WARNING

Moisture from rain or condensation must not be allowed to accumulate in the firebox or ash pan during the off season. Failure to perform preventive maintenance may result in corrosion damaging the boiler resulting in possible severe property damage.

MAINTENANCE (Cont.)

BEGINING OF SEASON:

- **Chimney:** Remove cap from chimney. Inspect chimney. Ensure chimney is not blocked (check for animal or bird nests).
- **Loading Door:** Oil door hinges and latch. Tighten Handle Nut. Inspect Gaskets. Verify that door seals tightly (apply thin coat of lipstick to loading flange, shut door, reopen and inspect marking on the gasket).
- **Plumbing:** Open all Isolation Valves. Ensure 1" fittings on both ends of tubing are tight. Ensure that all system Isolation valves are open.
- **Pump:** The circulator shipped with the appliance is water-lubricated. No oiling is required. Check other circulators in the system. Oil any circulators requiring oil, following circulator manufacturer's instructions. Over-oiling will damage the circulator.
- **Blower motor:** Place a few drops of S.A.E. 20 motor oil in each of the two oil cups.

WARNING

Use only **S.A.E. 20 motor oil** to lubricate the motor. Do not use universal household oils. Motor could be damaged, resulting in possible severe property damage.

- **Pressure:** Verify cold pressure is approximately 5 psi. Fill if necessary.
- **Water Chemistry:** Verify heating system water pH of 7.0 to 8.5. Adjust as necessary. Add corrosion inhibitor package to raise pH.
- **Anti-freeze:** Verify Anti-freeze percentage. Add as necessary.
 - In accordance with the Aqua-Therm warranty any hydronic system requires a minimum of 30% glycol. Directions for using the provided Antifreeze Tester:
 - When the percentage is at 30% propylene and 70% water the blue ball should float and the red one should sink.
 - If the mixture is over 30% propylene the red ball will start to float.
 - If blue ball sinks the mixture is not strong enough (less than 30%).

Failure to comply with manual and testing voids warranty.

*Note- These balls have temperature compensation built into them, ambient temperature does not affect the test.

- **Corrosion Inhibitor:** Verify level per manufacture's instructions..
- **Power:** Turn on power supply at the appropriate circuit breaker. Ensure that the pump is running.
- **Aquastat:** Inspect and test the Aquastat. Verify operation by turning Aquastat temperature below the appliance temperature. The **AQUA-THERM** should cycle off. Return Aquastat to original setting.
- **Air Vents:** Inspect automatic air vents . The cap must be unscrewed one turn to allow air to escape. If the air vent is leaking, remove cap and briefly push valve and then release to clean the valve seat. Replace cap by twisting all the way onto valve and then unscrewing one turn.
- **Start-up:** Review Start-up Checklist and Start-up Procedures.
- **Safety:** Review all Safety Precautions.
- **Housekeeping:** Verify that area is free of any **combustible materials**, gasoline and other flammable vapors and liquids or rags.

WARNING

Do not use **petroleum-based cleaning or sealing compounds** in the heating system. Severe damage to the heating system will occur, resulting in substantial property damage.

WARNING

Eliminate all system leaks. Continual fresh makeup water will reduce appliance life. Minerals can build up in the appliance, reducing heat transfer, overheating the metal. Leaking water may also cause severe property damage.

MAINTENANCE (Cont.)

DANGER

Electrical shock hazard — Turn off power to the appliance before any service operation on the appliance except as noted otherwise in this instruction manual. Failure to turn off electrical power could result in electrical shock, causing severe personal injury or death.

Pressure (Safety) Relief Valve

DANGER

Failure to re-inspect the Pressure Relief Valve as directed could result in unsafe pressure buildup, which can result in severe personal injury, death or substantial property damage.

AT LEAST ONCE A YEAR: Safety Relief Valves **must be operated** to ensure that waterways are clear.

Certain naturally occurring mineral deposits may adhere to the valve, rendering it inoperative. When manually operating the lever, water will discharge and precautions must be taken to avoid contact with hot water and to avoid water damage. Before operating lever, check to see that a discharge line is connected to this valve directing the flow of hot water from the valve to a proper place of disposal otherwise severe personal injury may result.

If no water flows, valve is inoperative. Shut down the appliance until a new relief valve has been installed.

AT LEAST ONCE EVERY THREE YEARS: Safety Relief Valves should be **re-inspected** by a licensed plumbing contractor or authorized inspection agency, to ensure that the product has not been affected by corrosive water conditions and to ensure that the valve and discharge line have not been altered or tampered with illegally.

Certain naturally occurring conditions may corrode the valve or its components over time, rendering the valve inoperative. Such conditions are not detectable unless the valve and its components are physically removed and inspected. This inspection must only be conducted by a plumbing contractor or authorized inspection agency — not by the owner.

VERIFY SYSTEM PRESSURE FOLLOWING TESTING OF RELIEF VALVES. ADD WATER TO SYSTEM AS NECESSARY.

DANGER

Failure to inspect and repair the above conditions can result in severe personal injury or death.

TROUBLESHOOTING

A. PROBLEM: Losing Pressure in System.

1. It is normal for pressure to vary with temperature.
2. Air bleeding out of system will cause pressure loss. When the appliance is first filled, it may take 3-4 days to purge all the air. Add water as needed until pressure stabilizes.
3. If pressure consistently drops, it indicates a leak in system. Check joints, fittings, relief valves, etc.

B. PROBLEM: Unit overheats.

1. Air leaks in the fire box can cause appliance to overheat. Ensure loading and ash door are sealing properly. Inspect door misalignment, worn gaskets or door handle nut looseness.
2. Draft fan shutter may not be operating properly. When the fan stops, the shutter should drop down completely covering fan intake.
3. Fan control Aquastat. Fan control Aquastat must not be set over 180°F. The Safety Aquastat is not adjustable and is set at 190°F.
4. Water is not circulating. If pump is not running or an isolation valve is shut, or an air lock is stopping circulation, appliance can overheat.
5. A backup power supply is recommended if frequent power outages are expected.

C. PROBLEM: Not Enough Heat in the structure being heated.

If the appliance reaches operating temperature and draft fan shuts off, it is working properly. (If draft fan does not shut off, see Problem D.) Check the following:

1. System water flow rate too low. This can be caused by:
 - a. Transfer Lines are too small in diameter.
 - b. Distance between the appliance and the heating system too great for the pump in use.
 - c. The circulating pump may not have enough capacity.
 - d. The system could be air bound. (See Problem E.)
2. The fan control Aquastat may be set too low. Set Aquastat up 10° but not over 180°F.
3. The house heating system may not be extracting enough heat from the water. Dust buildup on the baseboard fins or forced air heat exchanger system will reduce heat output.
4. The house heating system may not have enough capacity. More baseboards may need to be added to a hot water system. In a forced air system, more airflow through the heat exchanger will boost output.
5. Heat is being lost through underground pipes. Temperature coming into house should be no more than 2-3° different than temperature of water leaving the appliance.

To check for a flow problem, call your local Aqua-Therm Representative. Have the following information available: BTU need of home. If your existing furnace was adequately heating the home, look on furnace for BTU rating, diameter and length of underground pipe, model number of circulating pump and information from page 2 of this manual.

TROUBLESHOOTING (Cont.)

D. PROBLEM: Water Temperature Does Not Reach Fan Control Aquastat Setting. (Draft fan runs continuously.)

1. Wood may be too wet or green. Try mixing woods.
2. Check for obstructions in draft fan.
3. A partially clogged chimney may be restricting air flow in the appliance.
4. A buildup of ashes in the ash trough can restrict the exhaust of combustion air.
5. A buildup of ashes on top of the grates can restrict combustion air.
6. A buildup of creosote in the ash trough could plug the fan opening in the back, restricting combustion air.
7. Heat is being lost through underground pipes. Temperature coming into house should be no more than 2-3° different than temperature of water leaving the appliance.
7. Appliance is undersized for building being heated.
8. Pump undersized.

E. PROBLEM: No Water Flow

1. Air could be trapped in the line.
 - a. Repeat filling and venting procedure on page 37.
 - b. Temporarily add more water to system to bring pressure to around 15 lbs; the increased pressure will push air out of the Fill Cap. The Fill Cap will automatically bring pressure back to 18 psi or lower.
2. Pump is not running. You should be able to feel the vibration of pump when it's running.
 - a. Defective pump - check if installed properly (See page 28.) If installed incorrectly, pump will burn out. With 180° water circulating through pump, it will be hot to the touch.
 - b. Pump is not wired correctly. Refer to wiring diagram. (See page 25 or 27.)
3. Pump flanges are closed. Flanges are open when screw slot is parallel with the pipe.
4. The system is frozen somewhere.

F. PROBLEM: Excessive Creosote is Building up in Ash Trough.

1. Ash build up above grates or in ash trough area will cause restrictions in combustion air.
2. Appliance may not be burning hot enough.
 - a. Set fan control Aquastat to 180°F.
 - b. Set differential on fan control Aquastat to 20°. (See page 24 or 26.) This will let water temperature drop 20° before fan is started, causing a longer burn cycle.
3. Burning small pieces of extra dry wood can cause creosote. Try burning large pieces of wood for a few days.
4. If problem persists call your local Aqua-Therm Representative.

REPLACEMENT PARTS

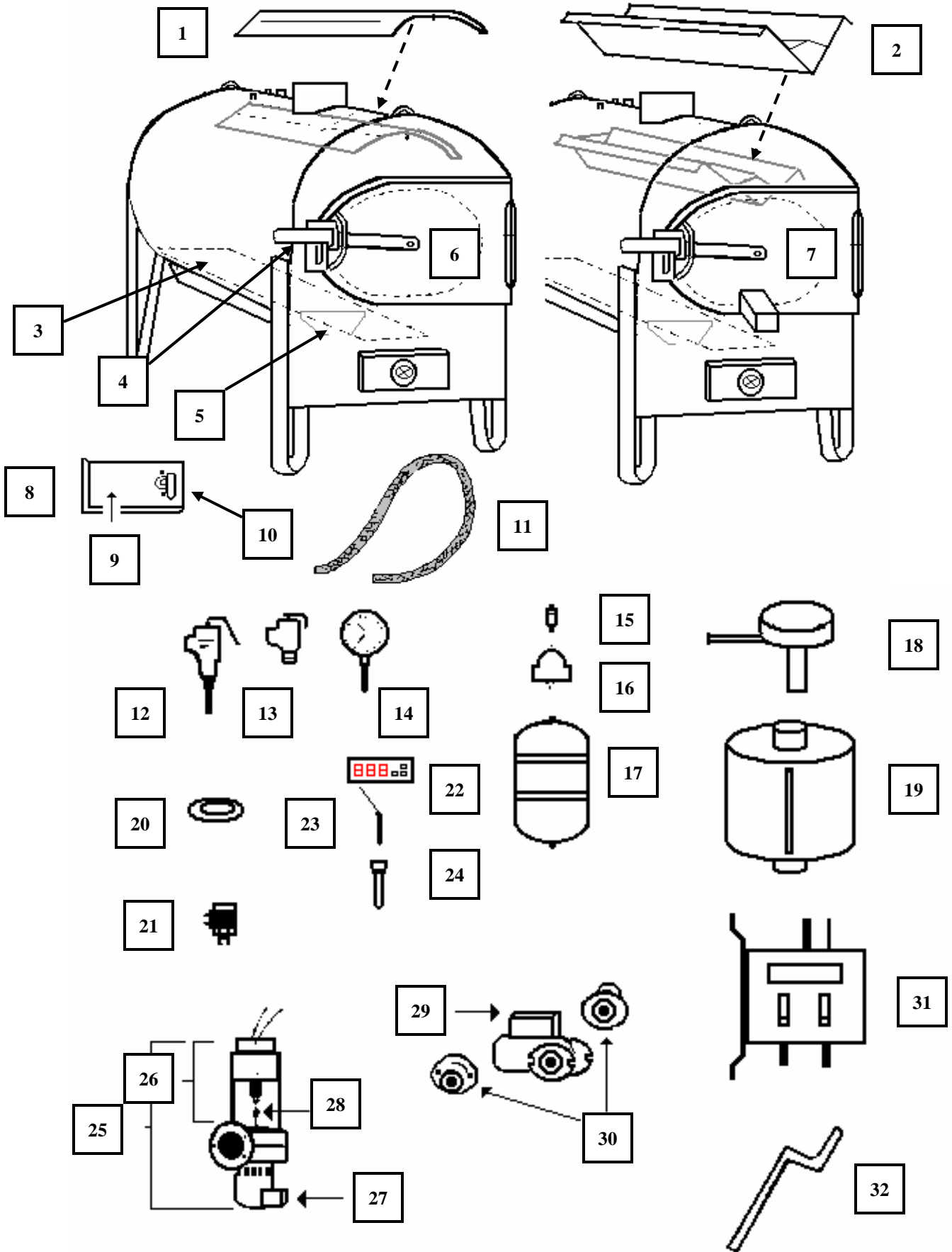

REPLACEMENT PARTS LISTING

	Units	P/N	Description
1	145 (AT)	20102	Upper Baffle Aqua-Therm
	275/345 (AT)	20103	
2	145 E-1		Upper Baffle ECO-One
	275/345 (E-1)	50002	
3	ALL	20156	Grate Section
4	ALL Unsheltered	30139	Loading Door Handle
	All Sheltered	40605	
5	145 (AT/ E-1)	40550	Lower Baffle
	275/345 (AT/E-1)	40551	
6	145 (AT)	20141	Loading Door Aqua-Therm
	275/345 (AT)	20142	
7	145 (E-1)		Loading Door ECO-One
	275/345 (E-1)	50004	
8	ALL	20130	Ash Door
9	ALL	30123	Ash Door Gasket
10	ALL	30124	Ash Door Latch
11	145 (AT/ E-1)	20111	Loading Door Gasket
	275/345 (AT/ E-1)	20112	
12	ALL	30149	Temperature Relief
13	ALL	30100	Pressure Relief
14	ALL Unsheltered	30101	Pressure Temp Gauge (Bottom Mount)
	ALL Sheltered	30146	Pressure Temp Gauge (Back Mount)
15	ALL	30111	Air Vent
16	ALL	40274	Air Scoop, 1" F NPT
		30110	Air Scoop, 1-1/4" F NPT
17	145 (AT/E-1)	30108	Expansion Tank
	275/345 (AT/E-1)	30109	
18	ALL		Fill Cap
19	ALL	40602	Open System Tank
20	ALL		High Temp Safety
21	ALL	30144	Solenoid

	Units	P/N	Description
22	ALL	35002	Digital Aquastat (w/ 6' sensor)
23	ALL		Aquastat Sensor, 6 ft
			Aquastat Sensor, 10 ft
24	ALL	30103	Aquastat Well
25	145 (AT/E-1)	20100	100 cfm Fan Assembly
	275/345 (AT/E-1)	20101	140 cfm Fan Assembly
26	ALL	20164	Shutter Assembly
27	145 (AT/E-1)	20159	100 cfm Fan
	275/345 (AT/E-1)	20160	140 cfm Fan
28	ALL	30145	Shutter Spring
29	ALL	30104	Pump, Taco 007
	ALL	30154	Pump, GF 15-58
30	ALL	40273	Isolation Pump Flange Set (1" F NPT)
		30106	Isolation Pump Flange Set (1-1/4" F NPT)
31	ALL AT	30164	Wiring Harness
	ALL E-1	50007	
32	ALL	30128	Ash Auger Crank

Not Pictured

ALL	30153	Auger Roll Pin
145 (AT/E-1)	20129	Fan Gasket, 100 cfm
275/345 (AT/E-1)	20131	Fan Gasket, 140 cfm
145 (AT/E-1)	40131	Insulation Kit
275 (AT/E-1)	40132	
345 (AT/E-1)	40133	
All Unsheltered	40244	Boiler Drain, 3/4 M NPT
All Sheltered	40248	Boiler Drain, 3/4 F NPT
ALL	30114	Surface Aquastat
ALL	30107	110 Relay
145 (AT/E-1)	20138	Auger
275/345 (AT/E-1)	20139	
ALL	30102	Analog Aquastat

NOTES

Lifetime Limited Warranty

On Aqua-Therm Outdoor Wood Burning Stoves With Stainless Steel Fireboxes

Aqua-Therm outdoor wood burning stoves are warranted by Aqua-Therm LLC to the original user against defects in workmanship under normal use for life, from the date of purchase.

This warranty is subject to the condition that the Aqua-Therm Product(s) must have been installed in accordance with manufacturers' instructions. This warranty is extended only to the first retail purchaser of the product and only to a product that has not been moved from its original installation site. Any warranty claims on outdoor wood burning stoves or component parts should be reported to the Aqua-Therm dealer from whom the product(s) were purchased. Any stove which is determined to be defective in material or workmanship within the first six (6) years and returned to Aqua-Therm, freight prepaid, will be repaired or replaced at Aqua-Therm's option at no charge to you. In years seven (7) through the life of the product Aqua-Therm will pay a prorated share of any repair or replacement cost. The proportionate charge will be equal to the appropriate percentage of the list price of the product at the time the warranty claim is made, and will be determined as follows: 7th year – 50 %; 8th year – 45%; 9th year – 40%; 10th year – 35%; 11th year – 30%; 12th year – 25%; 13th year – 20%; 14th through 19th years – 15%; 20th year and beyond – 10%.

All components: fans, baffles, pumps, aquastats, relays, gauges, relief valves, expansion tanks, heat exchangers, etc. are warranted by their manufacturers. In addition, Aqua-Therm warrants the original factory installed components for 1 year from date of purchase.

In addition to the warranty above, the Aqua-Therm warranty does not cover:

1. Components that are part of the heating system (products) but were not furnished by Aqua-Therm as a part of the heating system (products).
2. The workmanship of any installer of Aqua-Therm product(s). In addition, this warranty does not assume any liability of any nature for unsatisfactory performance caused by improper installation.
3. Any costs for labor for removal and reinstallation of the alleged defective stove or part, transportation to Aqua-Therm, if necessary, and any other materials necessary to perform the exchange.
4. Any products that have a failure or malfunction resulting from improper or negligent operation, accident, abuse, freezing, over temping, poor water quality, misuse, unauthorized alteration or improper repair or maintenance. Improper adjustments, control settings, care or maintenance. Information is in the installation manual and other printed/technical information provided with the product or direct from Aqua-Therm or www.aqua-therm.com.

NOTE: THE WARRANTY DESCRIBED HEREIN IS IN LIEU OF ALL OTHER WARRANTIES, EXPRESS OR IMPLIED, INCLUDING BUT NOT LIMITED TO ANY IMPLIED WARRANTIES OF FITNESS FOR A PARTICULAR PURPOSE AND MERCHANTABILITY. AQUA-THERM EXPRESSLY DISCLAIMS AND EXCLUDES ANY LIABILITY FOR CONSEQUENTIAL, INCIDENTAL, INDIRECT OR PUNITIVE DAMAGES FOR BREACH OF ANY EXPRESS WARRANTY. For prompt product warranty claims, notify the Aqua-Therm dealer from whom the product was purchased. If this action does not result in warranty resolution, contact Aqua-Therm, 48301 State Hwy 55, Brooten, Minnesota 56316, with details in support of the warranty claim. Alleged defective part(s) must be returned through the same dealer channel in accordance with the Aqua-Therm procedure currently in force for handling returned goods for the purpose of inspection to determine cause of failure. Aqua-Therm will furnish new part(s) to an authorized Aqua-Therm dealer who, in turn will furnish the new part(s) to the purchaser. If there are any questions about the coverage of this warranty, contact Aqua-Therm at the address above.

Corrosion inhibitor must be used and maintained for warranty to remain in effect. This necessitates annual testing (at least once yearly) and adjust (if necessary) the corrosion inhibitor balance.

Owner's registration card must be completed and returned to Aqua-Therm within 30 days from purchase for warranty to be in effect.

OUTDOOR WOOD FURNACE BEST BURN PRACTICES

1. Read and follow all operating instructions supplied by the manufacturer.
2. **FUEL USED:** Only those listed fuels recommended by the manufacturer of your unit. Never use the following: trash, plastics, gasoline, rubber, naphtha, household garbage, material treated with petroleum products (particle board, railroad ties and pressure treated wood), leaves, paper products, and cardboard.
3. **LOADING FUEL:** For a more efficient burn, pay careful attention to loading times and amounts. Follow the manufacturer's written instructions for recommended loading times and amounts.
4. **STARTERS:** Do not use lighter fluids, gasoline, or chemicals.
5. **LOCATION:** It is recommended that the unit be located with due consideration to the prevailing wind direction.
 - Furnace should be located no less than 100 feet from any residence not served by the furnace.
 - If located within 100 feet to 300 feet to any residence not served by the furnace, it is recommended that the stack be at least 2 feet higher than the peak of that residence.

Chimney Height Installation Scenario

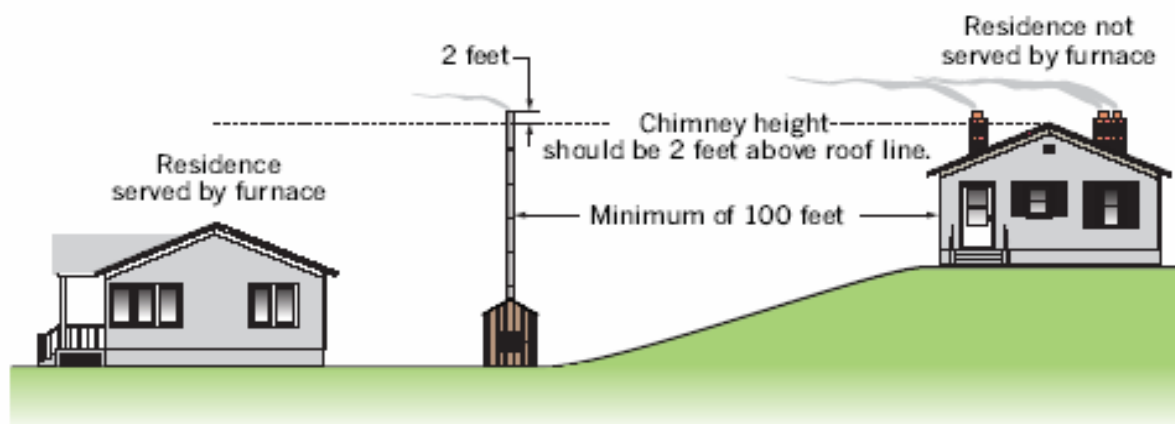

6. Always remember to comply with all applicable state and local codes.



OUTDOOR FURNACE MANUFACTURERS CAUCUS