

Thank you for purchasing Aqua-Floor Hydronic Radiant Floor Heating (HRFH) components from Aqua-Therm. Aqua-Therm has been in the hot water heating business since 1983. They also manufacture the Aqua-Therm outside wood burning boiler.

This manual is designed to serve as a guide to the installation of Hydronic Radiant Floor Heat. It assumes that the design work has already been done (heat loss, zoning, pumps, controls etc.)

The installation of the tubing and components is quite simple. Nevertheless, we recommend that the instructions be carefully read and followed.

If you have any questions on the installation of the tubing or other components, please contact our service department or your local dealer.

Aqua-Therm

48301 State Hwy 55
Brooten, Minnesota 56316
(320) 346-2264

Table of Contents

Insulation	3-4
Tubing Layout Patterns	5-9
Above Subfloor Installations	10
Underneath Subfloor Installations	12-14
Site Preparation	15
Manifold Location	16
Installation Tips	17-18
Tubing Installation	19-23
Pressure Testing the System	24
Pouring Concrete	25
3-Way Mixing Valve Installation	26
Plumbing	27-31
Wiring Thermostats to Zone Valves	32
Zone Circulating Pump Mounting	33-34
Wiring - Zone Circulating Pump	35
System Start-Up	36-37
Freeze Protection	38
Floor Coverings	39

Floor Coverings

Wood Flooring - The wider the board the more chance of gapping during seasonal changes. It's critical that the moisture content of the wood be 8% or less. It's wise to consult a flooring specialist before deciding on type and width of material to use.

Vinyl or Tile Flooring - Use only material that is rated for radiant floor heat. Flooring not designed for radiant heat can discolor.

Carpet and Pad - Selecting carpet and pad materials with low insulative (R) values is important. The lower the R value, the better the heat transfer. A carpet and pad that has a combined R value of 3 or greater can restrict heat transfer in that area.

NOTE: Interior door sills and interior partition walls should be glued down instead of using mechanical fasteners. This prevents the possibility of damaging tubing.

Freeze Protection:

You may choose to protect your system with an anti-freeze solution. Boiler anti-freeze, propylene glycol is recommended. Check instructions with anti-freeze for recommended dilution percentage.

To calculate water in the system:

1/2" tubing holds approx. 1 gallon per 100 feet

3/4" tubing holds approx. 2.5 gallons per 100 feet

1" tubing holds approx. 4.0 gallons per 100 feet

Insulation

Heat does not rise--hot air rises. This means the heat produced in a radiant floor installation without insulation under it will travel up, down and sideways. It is essential to have adequate perimeter insulation as well as insulation and a vapor barrier under the slab.

A perimeter insulation of 2" rigid Polystyrene is recommended for all installations. (Diagrams not to scale).

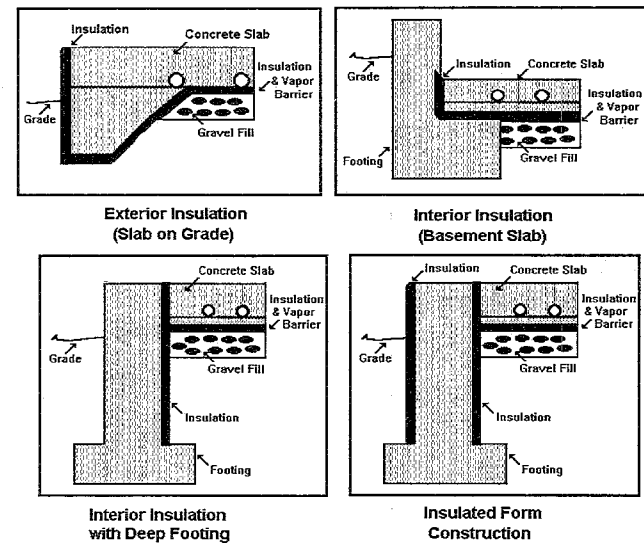

There should be a minimum of 1" insulation under the entire slab with a vapor barrier under the insulation.

The first tube should be placed about 12" from inside wall. By overhead doors, first tube should be placed in 6" to 9" to prevent freezing of door.

**Under Slab Insulation Comparison
40 x 60 Shop**

	No Insulation	1" Insulation	2" Insulation
Est. Annual Fuel Cost LP @ .95/gal	2,168.31	1,784.95	1,737.04
Annual Savings with insulation		383.36	431.27
Cost of insulation		649.50	1,200.00
Time needed to pay for insulation		1.7 years	2.8 years

Note: Fuel savings between 1" and 2" is \$47.91 / year.

Step 6: Open relief valve on boiler to allow air to escape.

Step 7: Fill one loop at a time until all loops are full.

Step 8: Continue adding fluid until a good stream of water only, no air, flows out of pump flange "B". This might take 5 gallons or more of water coming out.

Step 9: Close pump flange "B" and continue filling to approximately 10 psi (cold). When boiler comes up to desired operating temperature, the pressure should be approximately 12 - 15 lbs.

Step 10: Mount pump to flanges "A" and "B".

Step 11: Open pump flanges "A" and "B".

In applications where the tubing is exposed to freezing temperatures, you should protect with anti-freeze.

To bleed a system with anti-freeze mixture, follow the same procedure as using plain water except catch the anti-freeze solution that comes out of pump flange "B". Solution can be put back into the system with a transfer pump.

Over the next couple days, the rest of the air will escape out the auto air vent. This may affect pressure; making it necessary to pump more fluid into the system.

System Start-Up

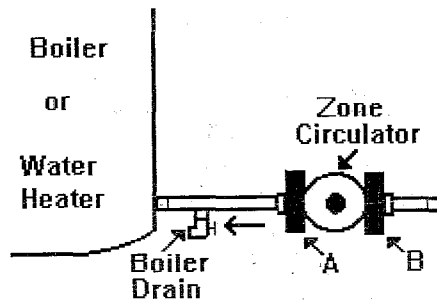

Warning - Do not fill tubing with plain water in cold concrete. The concrete can be cold enough to freeze water instantly. Mix anti-freeze at this time.

It is important to bleed air correctly when you are first filling the system. The goal is to push all the air ahead of the water and out of the floor and boiler. To accomplish this, the water must push the air in one direction, through the system and out the other end.

Step 1: Close pump flange "A"

Step 2: Remove pump from system.

Step 3: Open pump flange "B". Water can only move in one direction, it will push air all the way through the system and out pump flange "B".

Step 4: At the cold manifold, shut all the loops except one.

Step 5: Attach hose to boiler drain and turn on water.

Tubing Layout Patterns

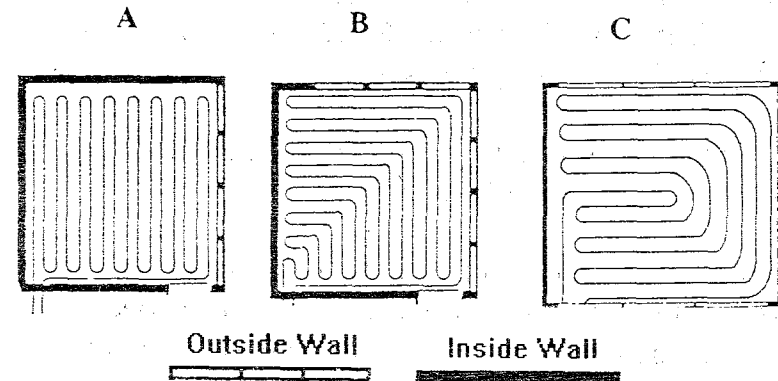

Patterns A, B and C are laid out so that the highest water temperature will be directed to the areas with the most heat loss; such as outside walls, large windows, doors, etc. The highest water temperature will be at the beginning of the loop. These patterns can be modified in many ways to accommodate different applications.

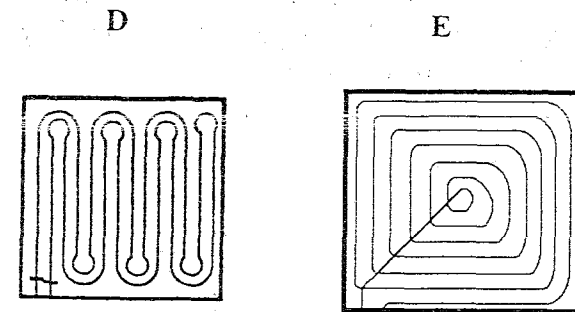

Patterns D and E are used in areas where BTU requirements are fairly constant throughout the area. This works well in large living areas or the center of a shop.

Sample Layout:

In this example we use A & B patterns with 12" on center. When using 12" centers, the tubing ratio is 1 foot of tubing for 1 square foot of space.

Shop is 1800 sq. feet which will require 1800' of tubing. We will use 6 - 300' rolls.

When tubing is put in concrete, the entire slab will be heated. As long as the correct amount of tubing is used, tube spacing does not have to be exact in order to have even heat.

To calculate tubing layout:

- 1) Determine manifold location. We chose the middle of the 60' South wall.
- 2) We divided the building from North to South into 3 bays. Two loops will be used per bay. Center bay should be approximately 20% larger than outside bays.

Sample: We divided it 19' x 22' x 19'.

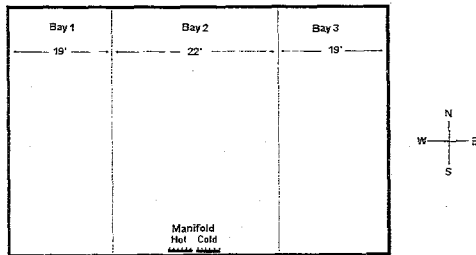

Not to scale

Wiring - Zone Circulator

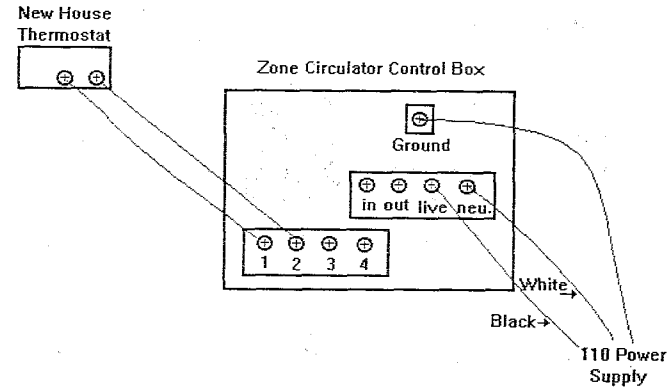

Control box is located on zone circulating pump.

- Step 1.** Bring the 110 volt power supply to junction box on zone circulator.
- Step 2.** Connect the black wire from power supply to the *Live* terminal.
- Step 3.** Connect the white wires from the power supply to the *Neutral* terminal.
- Step 4.** Connect ground wire from the power supply to ground screw.
- Step 5.** Connect thermostat wires to screws 1 and 2 on zone circulator.
- Step 6.** Contacts 3 & 4 are end switches, usually not used.

Isolation Pump Flanges

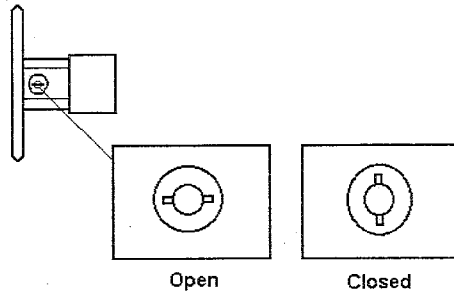

Mount flange so that screw is accessible. When slot is parallel to pipe, valve is open. When it is parallel to flange, it is closed.

Use an allen wrench or wide screwdriver to open and close valve.

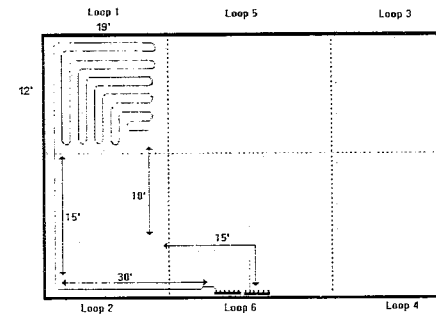

Not to scale

- 3) Calculate amount of tubing needed for supply and return to manifold. Start with loop farthest from manifold.

Sample: South wall 30' plus West wall 15' equals 45' on hot (supply) side that will be heating loop #2's area. On cool (return) side we have 15' plus 10' to return to manifold.

Total tubing not used in loop #1's area:

$$30' + 15' + 15' + 10' = 70'$$

50' will be heating loop #2's area and 20' will be laid in loop #6's area.

- 4) Loop #1 length 300' less 70' leaves 230' of tubing. With 12" spacing, this will cover 230 square feet.
- 5) Loop #1 width is 19'. Divide 230 square feet by width of 19' = 12' length. Loop #1's area will be 19' x 12'. Chalk off an area about 19' x 12' in Northwest corner and start rolling out tubing.

- 6) Start at the hot manifold and roll loop #1 along South wall then up West wall. Use the 'B' pattern. Do not return the loop back to the cold manifold until you lay loop #2. Start 12" from inside finished wall. It is common to run spacing at 9" on center for the first couple runs at cold walls. Then graduate to 12" and toward center of building you will be at 15" spacing.

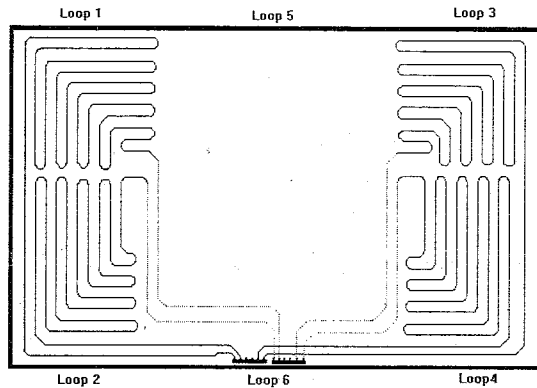

Not to scale

- 7) Start loop #2 at hot manifold and roll out also using the 'B' pattern with hot line starting along outside wall. Loop #2 will cover an 18' x 19' area. Maintain 12" spacing between loop #1 and loop #2.
- 8) Bring return from loop #2 back to cold manifold. Then bring return from loop #1 alongside loop #2 to cold manifold.

Zone Circulating Pump Mounting

Circulator must be mounted in proper position. Failure to mount properly can result in pump motor burning out due to lack of lubrication.

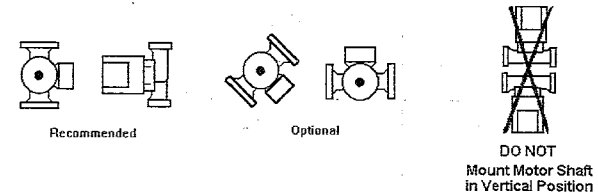

Circulator must be mounted with the motor in a horizontal position.

Body has an arrow in the front that indicates direction of flow. To rotate body, remove the four body bolts, rotate body and replace bolts. Make sure the junction box is NOT located underneath the circulator. (The junction box must NOT be located in the 6 o'clock position, as viewed from the motor end.) When the system is operating, the pump normally is quite warm to the touch.

DO NOT mount motor shaft in vertical position.

Wiring Thermostats to Zone Valves

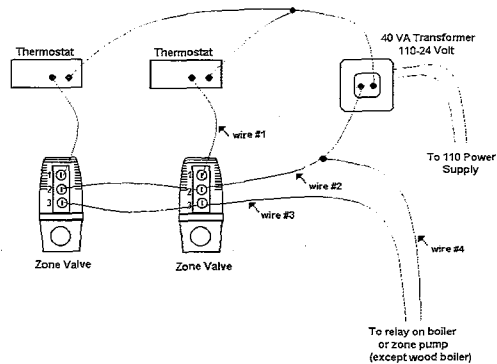

A few things to keep in mind, when working with Taco Zone Valves, are:

1. They do not have an isolated end switch.
2. They are slow to respond to a thermostat signal, it takes 2-3 minutes to activate the boiler or pump or even to open and close. Time may increase if several activate at the same time.
3. The transformer on the boiler and the auxiliary transformer will not fight each other during normal use.
4. They are a four wire valve but only three terminals are used.
5. Never remove zone valve head or move manual lever until the power has been shut off for at least four minutes.
6. Never activate zone valve head when it is removed from the zone valve body.

When wiring the transformer and thermostats, please wire as shown in diagram above.

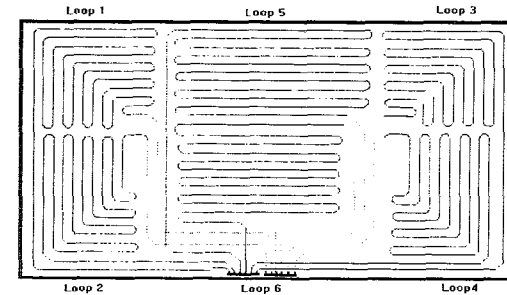

Not to scale

- 9) Lay loop #3 in same manner as loop #1. Lay loop #4 in same manner as loop #2.
- 10) Lay loop #5 using pattern A.
- 11) Lay loop #6 in reverse. Start with the cold side instead of hot, using pattern A. From cold manifold lay tubing first along loop #5 and work back towards the manifold.
- 12) Fasten the tubing approximately every 4' to 5'.

Sq ft ÷ available tubing x 12 = on center spacing

Example: 2000' ÷ 2500' x 12 = 9.6" on center spacing

Above Subfloor Installations

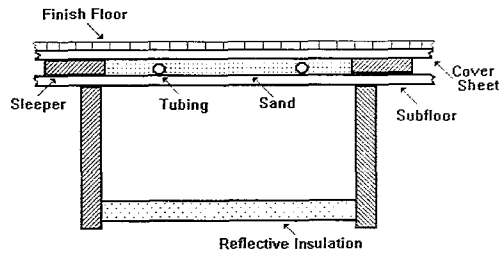

Sleepers can be glued and nailed to the subfloor. Lay the tubing in gap between the sleepers. The gaps can then be filled with sand to increase heat holding capacity. After the tubing is pressure tested, the floor is covered with a plywood cover sheet. The sleeper and cover sheets should be glued and nailed to avoid the possibility of squeaky floors. When tubing passes through the sleeper, metal nailer plates must be used. Use 1" x 2" or 2" x 2" sleeper with 1/2" tubing.

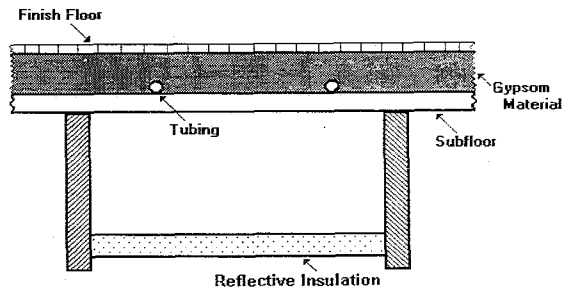

A gypsum-based underlayment can be used for an above subfloor installation. After the tubing has been fastened to the floor and pressure tested, an installer would pour the gypsum material. This material will weigh approximately 14.4 lbs per square foot for a 1 1/2" thick layer. Flooring can be attached directly to the gypsum.

Plumbing Multiple Zones on Same Level

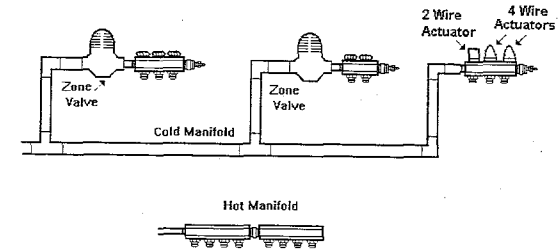

When installing more than one zone on the same level, use one hot manifold. The cold manifold is split for each zone. Zone valves, which are controlled by wall thermostats, are installed on each cold manifold.

This example is a 4 zone set up. Two regular zone valves are used. Two 4 wire actuators are used, and one 2-wire actuator is used. The two regular zone valves are controlling multiple loops. The one 4-wire actuator is controlling a single loop. The other 4-wire actuator is controlling two loops with help from the 2-wire actuator.

Wiring Actuators

4 - Wire - with two wire thermostats

1. Connect blue wire to one side of thermostat
2. Connect brown wire to one side of transformer
3. Connect two green wires, which are the end switch, to the "t" terminals on boiler.

2 - Wire - is always piggy backed with 4-wire

1. Connect blue wire to blue wire
2. Connect brown wire to brown wire

Plumbing with 3-Way Mix Valve in a Two Temperature System

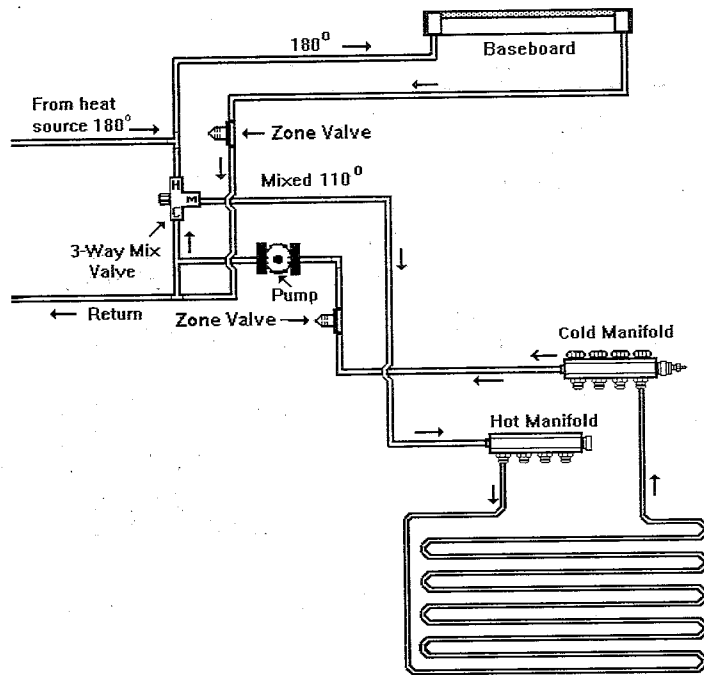

A bypass loop may be needed with some types of boilers to prevent return water, that is too cool, from shocking the boiler. Check with boiler manufacturer for proper installation.

The pump must be located between cold manifold and tee in order for the mix valve to work.

Lightweight Concrete

An alternative to gypsum based underlayments is lightweight concrete. Lightweight concrete can be mixed by local concrete suppliers and is poured, leveled and troweled in the same manner as standard concrete. One and a half inches of lightweight concrete will weigh 12 ½ to 14 lbs.

Recipe for Lightweight Concrete¹

Portland Cement (94 lb. bags)	5.5 bags
Sand	1160 pounds
Water	37 gallons
Norlite lightweight aggregate (3/8")	900 pounds
Hycol (water reducing agent)	15.5 ounces
Daravair (air entraining agent)	4.0 ounces
WRDA-19 (superplasticizer)	51.7 ounces
Fiber mesh	1.5 pounds

This will make 1 cubic yard which will cover 210 square feet of floor when applied at a thickness of 1.5 inches.

¹Modern Hydronic Heating by John Siegenthaler, PE; Delmar Publications, 1995

Underneath Subfloor Installations

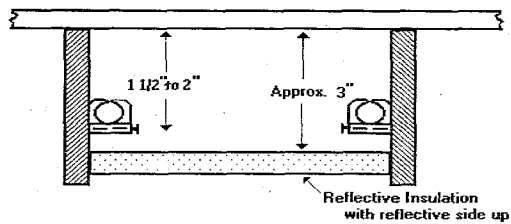

Tubing can be installed underneath the subfloor by attaching tubing to the joist with a strap hanger. An insulation with reflective back must be installed 3" below subfloor with the reflective side facing up.

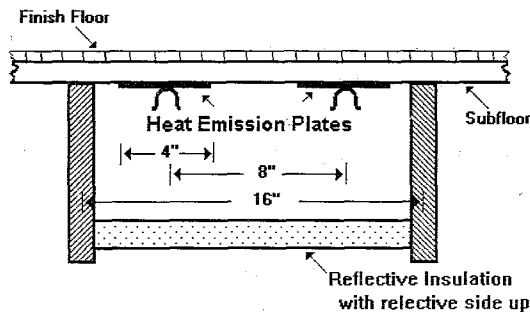

Aluminum heat emission plates can be installed under the subfloor. These are usually 4" wide and come in 48" sections. Tubing can be snapped into place. The track will securely hold tubing. The aluminum gives extra heat transfer; however, it adds considerably to the cost of the project. With this method, you also need to install insulation below tubing.

Note: If the area under the subfloor is not heated, use an insulation with an R-value of 20-30. If the subfloor is above a heated area, an R-value of 11-13 is usually sufficient.

Plumbing a 3-Way Mix Valve and a Forced Air Coil with an Aqua-Therm Wood Burner

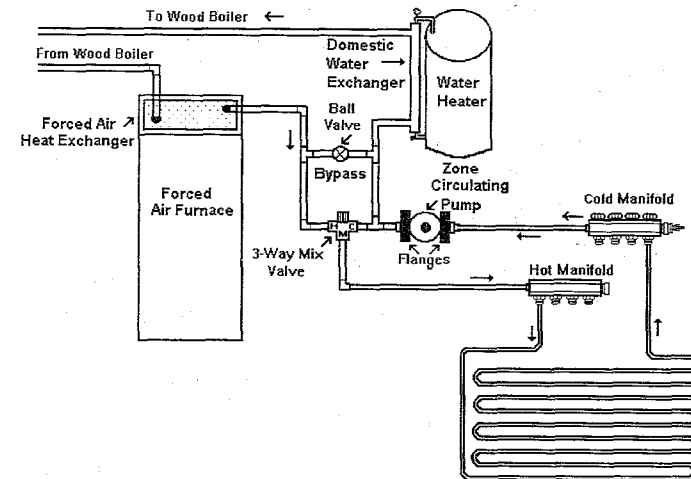

The ball valve in bypass should be closed when you initially fill the system to force the fluid through the floor. When up and running, it can be fully opened.

The pump must be located between cold manifold and tee in order for the mix valve to work.

Plumbing With 3-Way Mix Valve and Two Zones on Different Levels

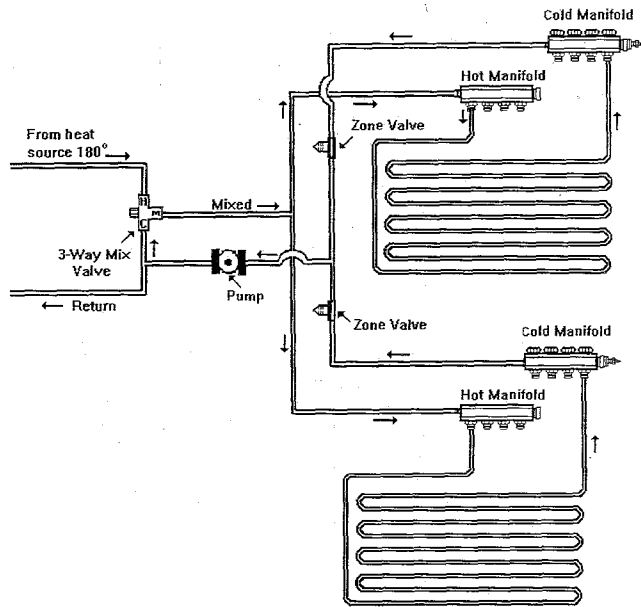

A bypass loop may be needed with some types of boilers to prevent return water, that is too cool, from shocking the boiler. Check with boiler manufacturer for proper installation.

The pump must be located between cold manifold and tee in order for the mix valve to work.

Installation Between Floor Joists

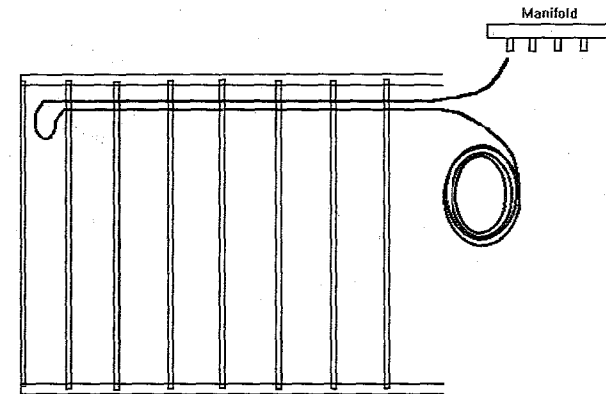

It will make it easier to install the tubing between the floor joist if you have a minimum of 3 people working together.

- Step 1: Drill two sets of holes in each joist along entire end. First hole should be 7/8" and second hole 1 1/4". (In no case should the bottom edges of the joist be drilled or notched.) Drill these holes in as straight a line as possible.
- Step 2: From the coil of tubing, take one end and pull through both sets of holes. Largest hole first. Bring end to the location of the manifold.
- Step 3: Pull the tubing into the first floor joist cavity about 2 to 3 feet. **Be very careful not to kink tubing.**

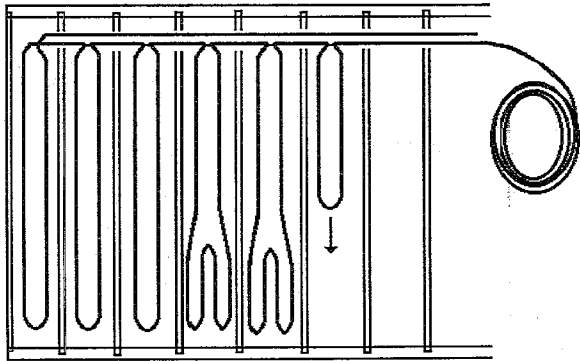

Plumbing to a Water Heater or Electric Boiler

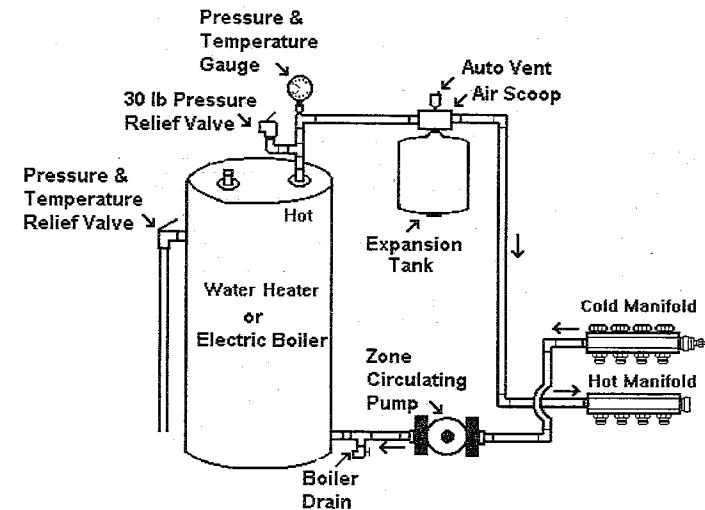

- Step 4: Flip the loop over 180°. Tubing will be crossed. This will help prevent kinking of tubing when pulling it through the joist.
- Step 5: Pull enough tubing through the joist to fill the cavity. Double up tubing by large windows or other areas of high heat loss.
- Step 6: Use tube hangers to hold the tubing in place.
- Step 7: Repeat steps 3 - 6 for the next cavity.
- Step 8: Continue doing one joist cavity at a time until floor is completed.

Note: These types of installation can be more susceptible to freezing on outside edges.

The temperature range on the water going into the floor should be 100° to 140°F.

NOTE - The small cap on the auto vent should be opened half way and it should remain open during operation of the heating system. The cold water inlet on top of heater should be capped off.

⚠ DANGER: Never operate water heater without properly installed 30 lb. pressure relief valve and temperature relief valve. Failure to use proper valve could result in an explosion.

3-Way Mixing Valve Installation

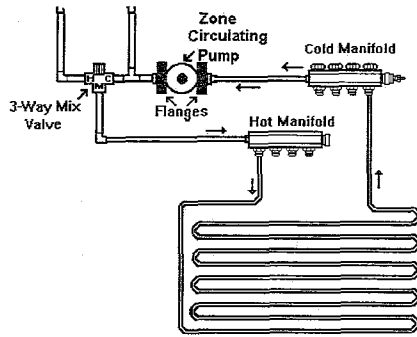

The 3-way mixing valve regulates the temperature in the floor by mixing cooler return water with the hot from the boiler. It will shut off supply to the floor in an overheat situation.

Important: The pump or zone circulator must be located between cold manifold and tee in order for the mix valve to work.

Site Preparation

To avoid damage to the pipe, the base for HRFH systems must be smooth, level, and free of sharp objects. The base must be tamped and very firm.

Place a moisture barrier of 6 mil polyethylene over the entire area. The insulation is placed on top of this.

Attach the tubing to the wire mesh or re-bar with wire or plastic ties. Secure tubing approximately every 5 feet. It can also be mounted directly on the insulation with screw clips.



Manifold Location

In most residential applications, the manifold is installed under a stairway, in a closet, or the utility room. It is best if it can be centrally located. Mount manifold a minimum of 12" above the finished floor to make air bleeding easier. **Do not put manifold in the concrete.**

A protector sleeve, of larger diameter utility pipe, should be used where the tubing comes out of the floor. This protects from power trowels, etc.

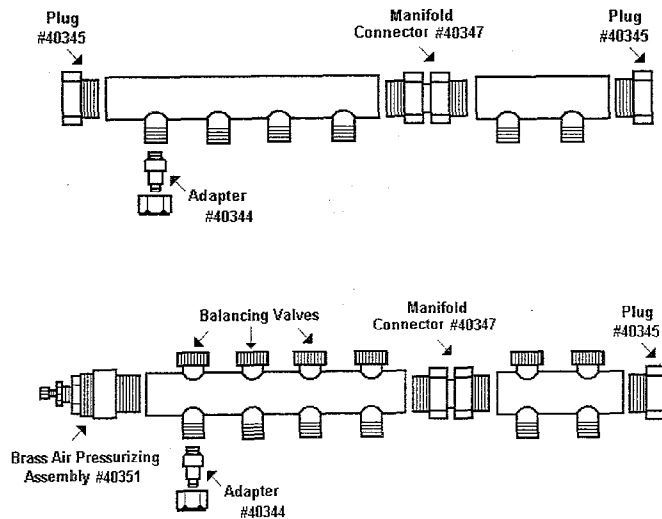

Pouring Concrete

Use care when pouring concrete to prevent damage to tubing. Avoid standing or walking on tubing as much as possible. When using a wheelbarrow, plywood should be laid over the tubes and used as ramps. Use care when dumping wheelbarrow to avoid kinking tubing.

Concrete should be thoroughly and carefully tamped to eliminate air pockets. A minimum of 3/4" of concrete is required over tubing for home applications; for shops, 1 1/4" should be used.

When an expansion joint or sawn control joint is needed, protect the tubing with a sleeve.

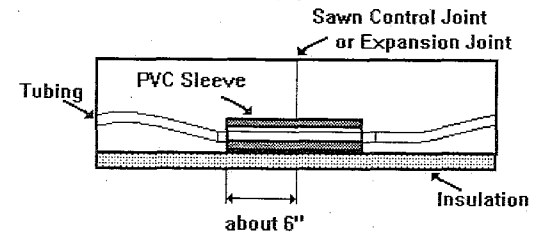

DO NOT try to cure new concrete by running heat through the tubes; this may ruin the concrete. Concrete cures at different rates, depending on humidity, etc. Check with your cement contractor. Allow a minimum of 7-10 days before putting heat into the floor.

Pressure Testing the System

The system must be pressure tested with air to approximately 60 psi and checked for leaks before pouring concrete. The complete manifold system should be soap tested. Mix warm water and liquid soap. Brush it on the fittings. If there is a leak, you will see bubbles forming when the air is pumped into the system. **Do not pressurize system with water when testing.**

Pressure should be maintained for 24 hours before concrete is poured. Maintain this pressure while concrete is being poured and until you hook manifold to heat source.

It's a good idea to inform your concrete contractor that you have the tubing pressurized. Check the pressure just before pouring and recheck during and after pouring to make sure the tubing has not been cut.

Installation Tips

- 1) Place automatic or manual bleeder on high point of system. This allows a place to bleed air.
- 2) If the auto air vent starts dripping fluid, it probably just needs to be cleaned. Depressurize system and remove main cap off vent. Remove debris from needle valve.
- 3) Do not place tubing too close to toilet flanges. The heat can affect the wax ring. (9" minimum)
- 4) In most cases, tubing under kitchen cupboards is not needed except a few runs under sink. Tubing under regular kitchen cupboards can melt chocolate.
- 5) If there are a lot of tight bends, try bending tubing around a coffee can, pulley, etc.
- 6) Metal nailer plates need to be used when the tubing passes through a 1 x 2 sleeper so a nail cannot penetrate tubing.
- 7) Do not fill tubing with **plain water in cold concrete**. The concrete can be cold enough to freeze water instantly. Mix in anti-freeze at this time.
- 8) We advise that you identify the loops off the manifold before you pour concrete so you know what part of the building each outlet is covering.
- 9) Nail down carpet bars can be your enemy.

10) 1/2" Tubing holds one gallon per 100 feet.

11) If you are placing tubing in sand under concrete, be sure to sleeve the tubing as it comes up through the concrete.

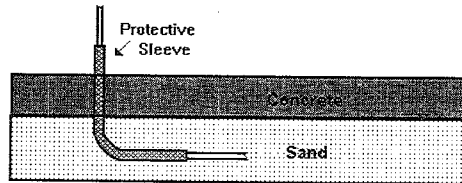

12) 300' is the maximum length to be run for 1/2" tubing.

13) If you are using 1" Pex for transfer lines, these should be insulated and placed under the insulation and concrete.

14) Normal temperature ranges of fluid in tubing are:

In concrete: 90° - 140°F.

Between floor joists: 160° - 180°F.

b. Take the manifold adaptors part # 40344 (two pieces) and slide the compression nut onto each loop.



c. Then bevel the inside of each tube with the bevel tool.



d. Take brass ferrule and insert into each pipe. Slide it on until the shoulder comes to the 3/8" mark.

e. Bring the compression nut up to brass ferrule, attach to manifold and tighten snug with wrench. Do not over tighten!

Step 5: Manifold assembly

- a. The manifold with the white knobs should be used as the cold manifold.
- b. The air pressurizing assembly should be placed on the cold manifold, opposite the boiler hook-up. This assembly will allow you to bleed air from system.
- c. Use plugs to go into three remaining ends of the manifolds.

Step 6: Slip protective sleeves over each tubing end. They fit somewhat snug, you may need to use soapy water to help slide them on.

Step 7: a. Attach the hot and cold manifolds to the mounting brackets. Mount the brackets to a solid surface. (Some people prefer to fasten tubing to manifolds before attaching manifolds to solid surface.) Shape the cold and hot ends so they come up vertical under outlets of respective manifolds. Cut end off square with plastic tubing cutter, approx. 1/8" below threaded outlet on manifold. Place a mark on each tube 3/8" down from top, this is how far the adaptors will slide on.

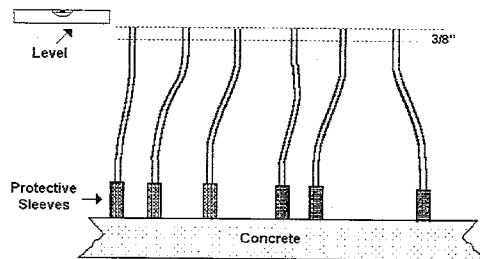

Tubing Installation

Step 1: Before installation, the tubing should be inspected for gouges, kinks, deep scratches or nicks. Replace entire loop if damage is found.

Step 2: Seal the ends of each loop to avoid debris getting into the tubing during installation.

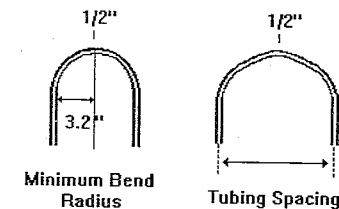

Do not bend 1/2 inch tubing tighter than 3.2 inch radius. When measuring tube spacing, measure from pipe centers.

Step 3: Secure one end of the loop to place where hot manifold will be installed. (DO NOT attach to manifold as fittings could be damaged when pipe is being laid out.)

Step 4: When unrolling tubing, stand the roll upright. Roll out like a tire. Do not pick up--leave against the base. Start laying out and tying the tubing, maintaining desired spacing. It works well to have one person unrolling tubing and a second person tying behind. The first tie should be within two feet of manifold. Tie approximately every 5 feet.

All loops will return to the manifolds. If tubing is short returning to the manifold, readjust tubing. DO NOT cut one loop to add to another. The tubing is metered every 3 feet.

Lay out entire roll according to selected pattern. (Refer to Aqua-Floor Homeowner Design Worksheet.)

For pattern D, triple the tube spacing for the first half of layout; the return half of the loop will go in between. Example: For 9" spacing, use 27" spacing on first half of loop. When using pattern D, lay out half of the tube; then use the remaining half to return.

Return each loop to opposite sides of the manifold. This will help to keep the flow balanced.

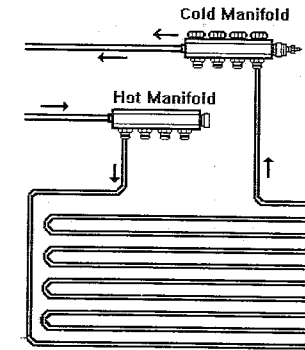

Be very careful not to kink tubing when unrolling and laying out. Tubing can be kinked and straightened one time. If you kink it a second time, you should replace loop. (Repair couplers cannot be used where they will be covered by concrete.) Avoid stepping on tubing whenever possible as it could kink where it crosses re-rod.